

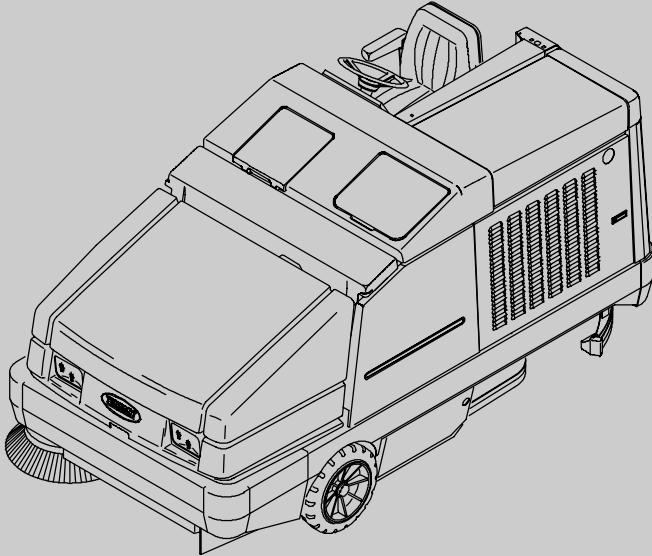

# 8410D

## Operator Manual



**The Safe Scrubbing Alternative®**

**ES® Extended Scrub System**

**North America / International**

[www.tennantco.com](http://www.tennantco.com)

MM391  
Rev. 15 (05-2007)





This manual is furnished with each new model. It provides necessary operation and maintenance instructions.

**Read this manual completely and understand the machine before operating or servicing it.**

This machine will provide excellent service. However, the best results will be obtained at minimum costs if:

- The machine is operated with reasonable care.
- The machine is maintained regularly - per the machine maintenance instructions provided.
- The machine is maintained with manufacturer supplied or equivalent parts.

	<b>PROTECT THE ENVIRONMENT</b> Please dispose of packaging materials, old machine components such as batteries, hazardous fluids such as antifreeze and oil, in an environmentally safe way according to local waste disposal regulations.
	Always remember to recycle.

<b>MACHINE DATA</b>	
Please fill out at time of installation for future reference.	
Model No. -	_____
Serial No. -	_____
Machine Options -	_____
Sales Rep. -	_____
Sales Rep. phone no. -	_____
Customer Number -	_____
Installation Date -	_____

**Tennant Company**  
PO Box 1452  
Minneapolis, MN 55440  
Phone: (800) 553-8033 or (763) 513-2850  
[www.tennantco.com](http://www.tennantco.com)



**CALIFORNIA PROPOSITION 65 WARNING:**

**Engine exhaust from this product contains chemicals known to the State of California to cause cancer, birth defects, or other reproductive harm.**

Thermo-Sentry and FaST-PAK are US registered and unregistered trademarks of Tennant Company.

Specifications and parts are subject to change without notice.

Copyright © 1996, 1997, 1999 - 2006, 2007 TENNANT Company, Printed in U.S.A.

**CONTENTS**

	Page		Page
SAFETY PRECAUTIONS .....	3	LATCHES .....	29
OPERATION .....	7	FUSE .....	29
OPERATOR RESPONSIBILITY .....	7	OPERATOR SEAT .....	30
MACHINE COMPONENTS .....	8	HOPPER SUPPORT BAR .....	30
SYMBOL DEFINITIONS .....	9	HOW THE MACHINE WORKS .....	31
CONTROLS AND INSTRUMENTS .....	11	FaST SCRUBBING SYSTEM .....	32
OPERATION OF CONTROLS .....	12	PRE-OPERATION CHECKLIST .....	33
DIRECTIONAL PEDAL .....	12	INSTALLING FaST PAK AGENT .....	34
BRAKE PEDAL .....	13	STARTING THE MACHINE .....	36
PARKING BRAKE PEDAL .....	13	SWEEPING, SCRUBBING, AND BRUSH	
HAZARD LIGHT SWITCH (OPTION) ..	13	INFORMATION .....	38
OPERATING LIGHTS SWITCH .....	14	SWEEPING .....	40
FILTER SHAKER SWITCH .....	14	STOP SWEEPING .....	41
HOPPER RAISE SWITCH .....	14	EMPTYING THE HOPPER .....	42
HOPPER DOOR SWITCH .....	15	FILLING THE TANKS .....	44
HOPPER LOWER SWITCH .....	15	SCRUBBING .....	46
SIDE BRUSH SWITCH .....	15	DOUBLE SCRUBBING .....	49
SWEEP VACUUM FAN SWITCH .....	16	STOP SCRUBBING .....	49
MAIN SWEEP BRUSH SPEED		DRAINING AND CLEANING THE TANKS	50
1 SWITCH .....	16	STOP THE MACHINE .....	52
MAIN SWEEP BRUSH SPEED		POST-OPERATION CHECKLIST .....	54
2 SWITCH .....	17	ENGAGING HOPPER SUPPORT BAR ..	55
CHARGING SYSTEM LIGHT .....	17	DISENGAGING HOPPER SUPPORT BAR	56
ENGINE OIL PRESSURE LIGHT .....	18	OPERATION ON INCLINES .....	57
ENGINE WATER TEMPERATURE		OPTIONS .....	58
LIGHT .....	18	VACUUM WAND (WET) .....	58
MAINTENANCE MODE LIGHT .....	18	MACHINE TROUBLESHOOTING .....	61
RECOVERY TANK FULL LIGHT .....	18	MAINTENANCE .....	64
CLOGGED FILTER LIGHT .....	19	MAINTENANCE CHART .....	64
HOPPER TEMPERATURE LIGHT -		LUBRICATION .....	66
THERMO SENTRY .....	19	ENGINE .....	66
OK LIGHT .....	19	REAR WHEEL SUPPORT .....	66
FUEL LEVEL GAUGE .....	20	FRONT WHEEL BEARINGS .....	67
HOURMETER .....	20	HOPPER LIFT ARM PIVOTS .....	67
ES SWITCH (OPTION) .....	20	HOPPER DOOR PIVOTS .....	67
DETERGENT FLOW SWITCH		REAR SQUEEGEE CASTERS (for	
(OPTION) .....	21	machines below serial	
EDGE SCRUB SWITCH .....	21	number 012215) .....	67
SCRUB SWITCH .....	22	HYDRAULICS .....	68
SQUEEGEE SWITCH .....	23	HYDRAULIC FLUID RESERVOIR .....	68
THROTTLE LEVER .....	23	HYDRAULIC FLUID .....	68
STEERING WHEEL .....	24	HYDRAULIC HOSES .....	69
HORN BUTTON .....	24	PROPELLING MOTOR .....	69
IGNITION SWITCH .....	24	ENGINE .....	70
TURN SIGNAL SWITCH (OPTION) .....	25	COOLING SYSTEM .....	70
STEERING COLUMN TILT HANDLE ..	25	AIR FILTER INDICATOR .....	71
CIRCUIT BREAKERS .....	26	AIR FILTER .....	71
MAIN SWEEP BRUSH DOWN		FUEL FILTER .....	72
PRESSURE KNOB .....	27	FUEL LINES .....	72
SIDE BRUSH DOWN PRESSURE		PRIMING THE FUEL SYSTEM .....	72
KNOB .....	27	BATTERY .....	73
SOLUTION FLOW SWITCH		BELTS AND CHAINS .....	74
(WITHOUT FaST) .....	27	ENGINE BELT .....	74
SOLUTION FLOW SWITCH (FaST) ..	28	STATIC DRAG CHAIN .....	74
FaST SWITCH .....	28		

# CONTENTS

	Page		Page
DEBRIS HOPPER .....	75	SPECIFICATIONS .....	99
HOPPER DUST FILTER .....	75	GENERAL MACHINE PERFORMANCE ..	99
REMOVING HOPPER DUST		FaST SYSTEM .....	100
FILTER .....	75	POWER TYPE .....	100
THERMO SENTRY .....	77	STEERING .....	101
SCRUB HEAD .....	77	HYDRAULIC SYSTEM .....	101
BRUSHES .....	77	BRAKING SYSTEM .....	101
MAIN SWEEP BRUSH .....	77	TIRES .....	101
REPLACING MAIN SWEEP BRUSH	78	MACHINE DIMENSIONS .....	102
CHECKING AND ADJUSTING MAIN		INDEX .....	103
SWEEP BRUSH PATTERN ....	79		
SIDE BRUSH .....	81		
REPLACING SIDE BRUSH .....	82		
SIDE BRUSH GUARD .....	82		
SCRUB BRUSHES .....	83		
REPLACING THE SCRUB BRUSHES	83		
SOLUTION SYSTEM .....	84		
RECOVERY TANK .....	84		
SOLUTION TANK .....	84		
FaST SYSTEM .....	85		
FaST SUPPLY HOSE CONNECTOR	85		
FaST SYSTEM FILTER SCREEN ..	85		
FaST SYSTEM AIR PUMP FILTER	85		
SQUEEGEES .....	86		
LEVELING THE REAR SQUEEGEE ..	86		
ADJUSTING REAR SQUEEGEE BLADE			
DEFLECTION .....	87		
SQUEEGEE BLADES .....	88		
REAR SQUEEGEE .....	88		
REPLACING OR ROTATING REAR			
SQUEEGEE BLADES .....	88		
SIDE SQUEEGEES .....	89		
REPLACING SIDE SQUEEGEE			
BLADES .....	89		
SKIRTS AND SEALS .....	90		
HOPPER LIP SKIRTS .....	90		
HOPPER SIDE SKIRT .....	90		
BRUSH DOOR SKIRTS .....	90		
REAR SKIRTS .....	91		
BRUSH DOOR SEALS .....	91		
HOPPER SEALS .....	91		
HOPPER INSPECTION DOOR SEAL .	91		
HOPPER DOOR SEALS .....	92		
HOPPER COVER SEAL .....	92		
HOPPER DUST SEAL .....	92		
HOPPER VACUUM FAN SEAL .....	92		
COVER AND DOOR SEALS .....	93		
BRAKES AND TIRES .....	93		
SERVICE BRAKES .....	93		
PARKING BRAKE .....	93		
TIRES .....	93		
REAR WHEEL .....	93		
PUSHING, TOWING, AND TRANSPORTING			
THE MACHINE .....	94		
PUSHING OR TOWING THE MACHINE	94		
TRANSPORTING THE MACHINE ....	95		
MACHINE JACKING .....	98		
STORING MACHINE .....	98		

## SAFETY PRECAUTIONS

The following precautions are used throughout this manual as indicated in their description:



**WARNING: To warn of hazards or unsafe practices that could result in severe personal injury or death.**

**FOR SAFETY: To identify actions that must be followed for safe operation of equipment.**

The machine is suited to sweep disposable debris. Do not use the machine other than described in this Operator Manual. The machine is not designed for use on public roads.

The following information signals potentially dangerous conditions to the operator or equipment:



**WARNING: Engine emits toxic gases. Severe respiratory damage or asphyxiation can result. Provide adequate ventilation. Consult with your regulatory authorities for exposure limits. Keep engine properly tuned.**



**WARNING: Raised hopper may fall. Engage hopper support bar.**



**WARNING: Lift arm pinch point. Stay clear of hopper lift arms.**



**WARNING: Moving belt and fan. Keep away.**



**WARNING: Flammable materials can cause an explosion or fire. Do not use flammable materials in tank(s).**



**WARNING: Flammable materials or reactive metals can cause explosion or fire. Do not pick up.**



**WARNING: Strong vacuum. Keep away from fan inlet when fan is running.**



**WARNING: Hot bumper. Keep away.**

#### CALIFORNIA PROPOSITION 65

**WARNING: Engine exhaust from this product contains chemicals known to the State of California to cause cancer, birth defects, or other reproductive harm.**

#### FOR SAFETY:

1. **Do not operate machine:**
  - Unless trained and authorized.
  - Unless operator manual is read and understood.
  - If it is not in proper operating condition.
  - In flammable or explosive areas unless designed for use in those areas.
  - In areas with possible falling objects unless equipped with overhead guard.
2. **Before starting machine:**
  - Check for fuel, oil, and liquid leaks.
  - Keep sparks and open flame away from refueling area.
  - Make sure all safety devices are in place and operate properly.
  - Check brakes and steering for proper operation.
3. **When starting machine:**
  - Keep foot on brake and directional pedal in neutral.
4. **When using machine:**
  - Use brakes to stop machine.
  - Go slow on inclines and slippery surfaces.
  - Use care when reversing machine.
  - Move machine with care when hopper is raised.
  - Make sure adequate clearance is available before raising hopper.
  - Do not carry passengers on machine.
  - Always follow safety and traffic rules.
  - Report machine damage or faulty operation immediately.
  - Follow mixing and handling instructions on chemical containers.
5. **Before leaving or servicing machine:**
  - Stop on level surface.
  - Set parking brake.
  - Turn off machine and remove key.

## **SAFETY PRECAUTIONS**

---

- 6. When servicing machine:**
  - **Avoid moving parts. Do not wear loose jackets, shirts, or sleeves.**
  - **Block machine tires before jacking machine up.**
  - **Jack machine up at designated locations only. Block machine up with jack stands.**
  - **Use hoist or jack that will support the weight of the machine.**
  - **Wear eye and ear protection when using pressurized air or water.**
  - **Disconnect battery connections before working on machine.**
  - **Avoid contact with battery acid.**
  - **Avoid contact with hot engine coolant.**
  - **Allow engine to cool.**
  - **Keep flames and sparks away from fuel system service area. Keep area well ventilated.**
  - **Use cardboard to locate leaking hydraulic fluid under pressure.**
  - **Use Tennant supplied or approved replacement parts.**
  
- 7. When loading/unloading machine onto/off truck or trailer:**
  - **Turn off machine.**
  - **Use truck or trailer that will support the weight of the machine.**
  - **Use winch. Do not drive the machine onto/off the truck or trailer unless the load height is 380 mm (15 in) or less from the ground.**
  - **Set parking brake after machine is loaded.**
  - **Block machine tires.**
  - **Tie machine down to truck or trailer.**

# SAFETY PRECAUTIONS

The following safety labels are mounted on the machine in the locations indicated. If these or any label becomes damaged or illegible, install a new label in its place.

**EMISSIONS LABEL - LOCATED ON THE SIDE PANEL OF THE OPERATOR COMPARTMENT.**



**ENGINE FAN AND BELT LABEL - LOCATED ON THE RADIATOR SHROUD.**



**FOR SAFETY LABEL - LOCATED ON THE SIDE PANEL OF THE OPERATOR COMPARTMENT.**

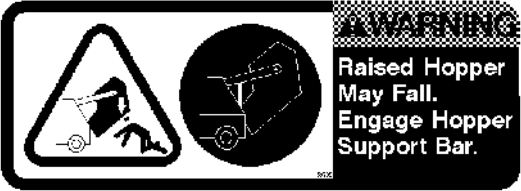
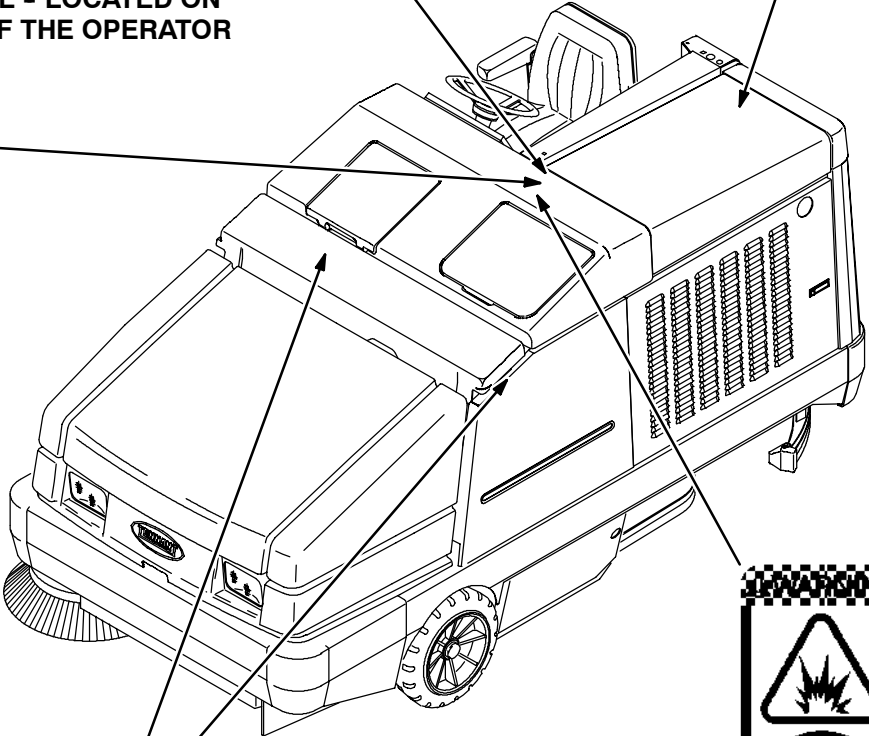

**HOPPER SUPPORT BAR LABEL - LOCATED ON THE HOPPER SUPPORT BAR AND ON BOTH HOPPER LIFT ARMS.**



**FLAMMABLE SPILLS LABEL - LOCATED ON THE SIDE PANEL OF THE OPERATOR COMPARTMENT.**

09078

# SAFETY PRECAUTIONS

**STRONG VACUUM LABEL - LOCATED ON THE VACUUM FAN HOUSING.**



**FLAMMABLE MATERIALS LABEL - LOCATED ON THE SOLUTION TANK COVER.**

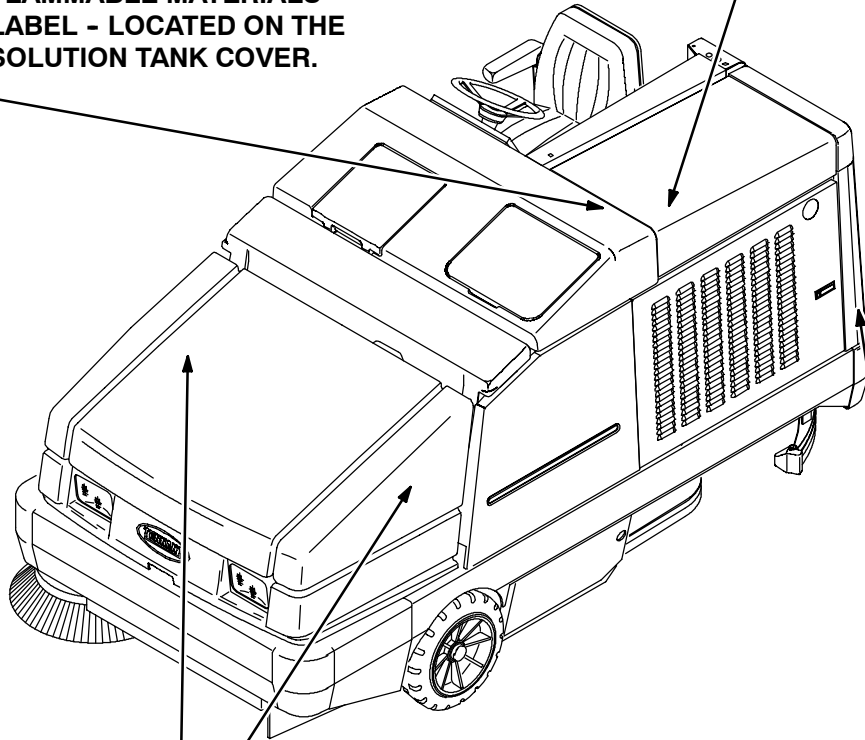
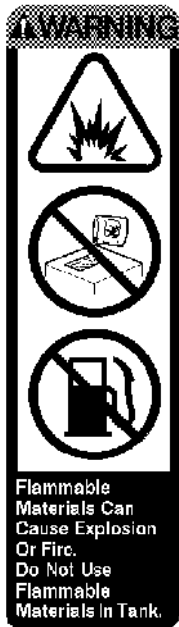

09078



**HOPPER LIFT ARMS LABEL - LOCATED ON BOTH HOPPER LIFT ARMS.**



**HOT BUMPER LABEL - LOCATED ON THE REAR LEFT PANEL.**



## OPERATION

---

**OPERATOR RESPONSIBILITY**

---

- The operator's responsibility is to take care of the daily maintenance and checkups of the machine to keep it in good working condition. The operator must inform the service mechanic or supervisor when the required maintenance intervals occur as stated in the *MAINTENANCE* section of this manual.
- Read this manual carefully before operating this machine.

**FOR SAFETY: Do not operate machine, unless operation manual is read and understood.**

- Check the machine for shipping damage. Check to make sure machine is complete per shipping instructions.
- Keep your machine regularly maintained by following the maintenance information in this manual. We recommend taking advantage of a regularly scheduled service contract from your Tennant representative.
- Order parts and supplies directly from your authorized Tennant representative. Use the parts manual provided when ordering parts.
- After the first 50 hours of operation, follow the recommended procedures stated in the *MAINTENANCE CHART*.

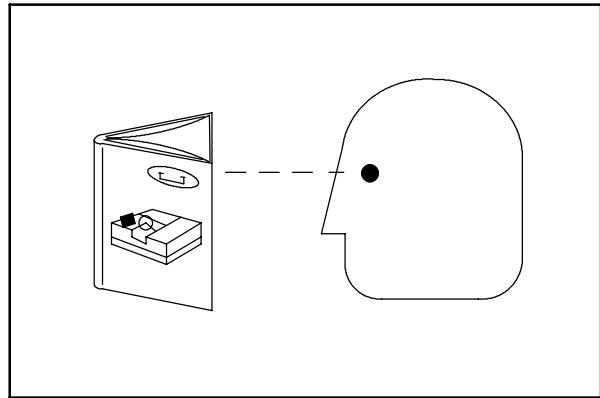

07324

## MACHINE COMPONENTS

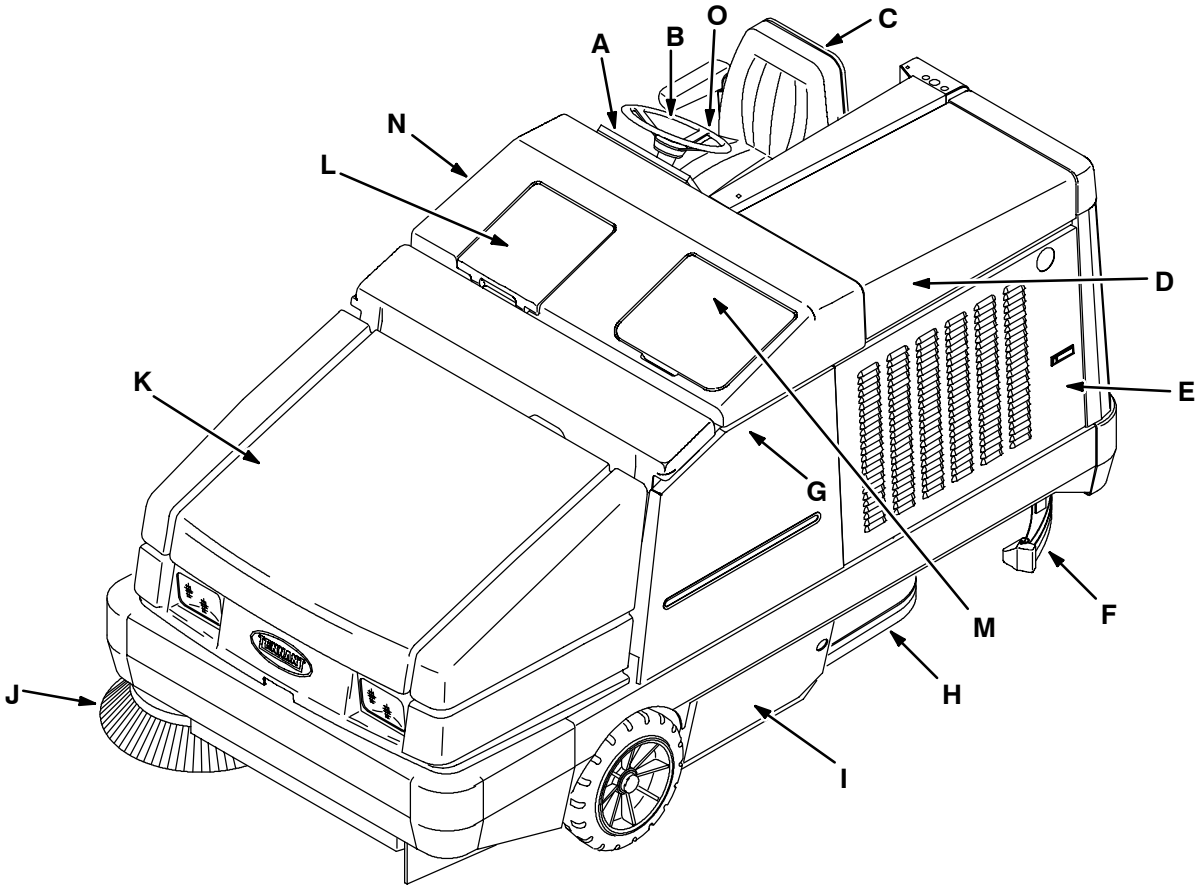

- A. Instrument panels
- B. Steering wheel
- C. Operator seat
- D. Engine cover
- E. Engine side door
- F. Rear squeegee
- G. Solution tank
- H. Side squeegee
- I. Sweeping brush access door
- J. Side brush
- K. Hopper cover
- L. ES pump cover
- M. Tank cover
- N. Recovery tank
- O. FaST solution system

09078

**SYMBOL DEFINITIONS**

These symbols identify controls, displays, and features on the machine:



Hazard light



Recovery tank full



Operating lights



Filter clogged



Filter shaker



Hopper temperature - Thermo Sentry



Hopper raise



Diagnostics



Hopper door close



Fuel



Hopper lower



Hourmeter



Side brush down and on



ES



Fan



Detergent flow



Main brush down and speed 1



Scrub brush edge clean



Main brush down and speed 2



Scrub brushes down and on



Charging system



Rear squeegee down and vacuum on



Engine oil pressure



Jackpoint



Engine water temperature



Horn



Maintenance mode



Parking brake

# OPERATION



Solution flow



Side brush down pressure light



Side brush down pressure heavy



Main sweep brush down pressure light



Main sweep brush down pressure heavy



Steering tilt



Circuit breaker 1



Circuit breaker 2



Circuit breaker 3



Circuit breaker 4



Idle



Circuit breaker 5



Circuit breaker 6



Circuit breaker 7



Circuit breaker 8



Circuit breaker 9



Variable pressure



Diesel fuel only



Hydraulic fluid only



Fast



Off

CONTROLS AND INSTRUMENTS

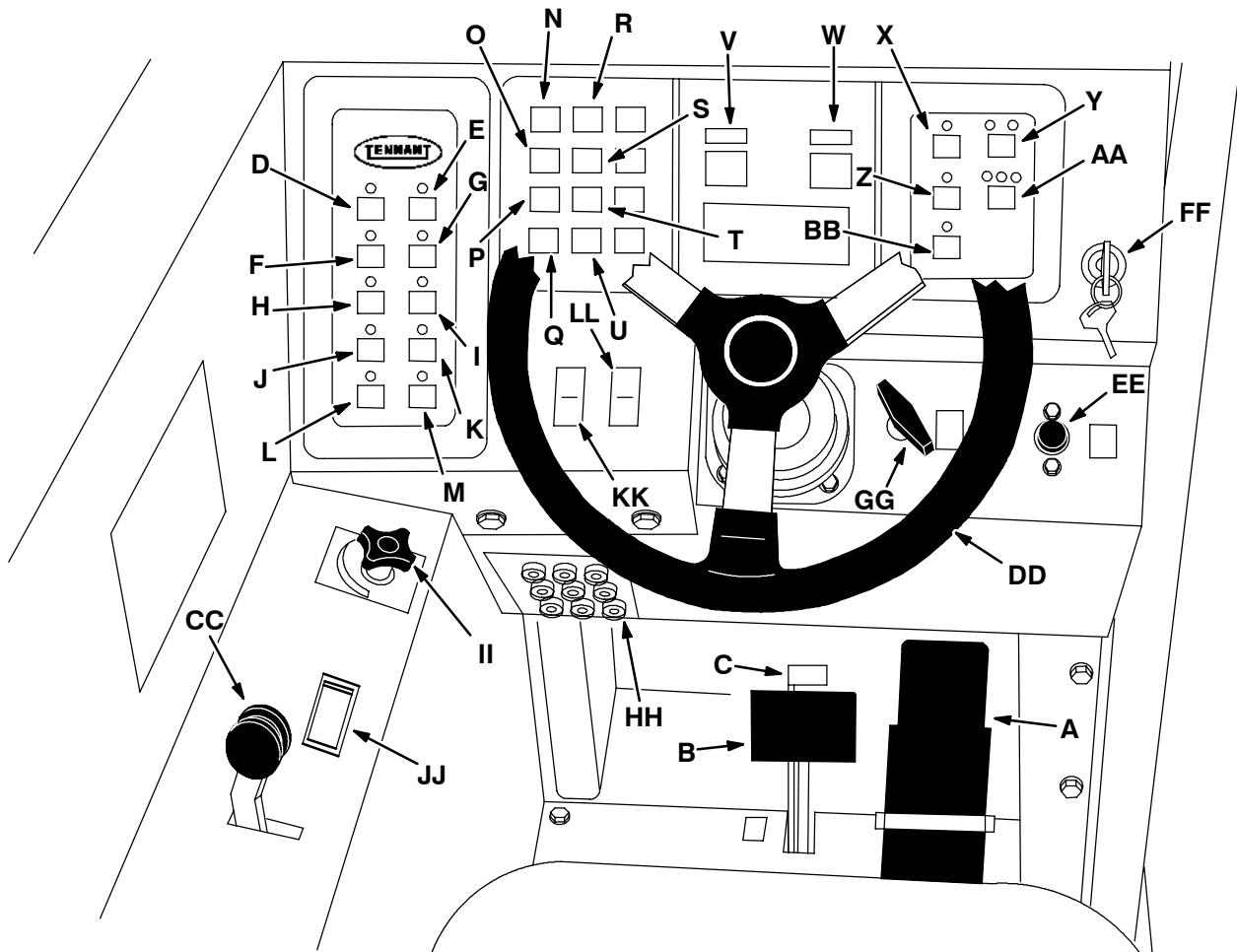

- |   |   |
|---|---|
| A. Directional pedal                        | U. OK light                             |
| B. Brake pedal                              | V. Fuel level gauge                     |
| C. Parking brake pedal                      | W. Hourmeter                            |
| D. Hazard light switch (option)             | X. ES switch (option)                   |
| E. Operating lights switch                  | Y. Detergent flow switch (option)       |
| F. Filter shaker switch                     | Z. Edge scrub switch                    |
| G. Hopper raise switch                      | AA. Scrub switch                        |
| H. Hopper door switch                       | BB. Squeegee switch                     |
| I. Hopper lower switch                      | CC. Throttle lever                      |
| J. Side brush switch                        | DD. Steering wheel                      |
| K. Sweep vacuum fan switch                  | EE. Horn button                         |
| L. Main sweep brush speed 1 switch          | FF. Ignition switch                     |
| M. Main sweep brush speed 2 switch          | GG. Steering column tilt lever          |
| N. Charging system light                    | HH. Circuit breakers                    |
| O. Engine oil pressure light                | II. Main sweep brush down pressure knob |
| P. Engine water temperature light           | JJ. Solution flow switch                |
| Q. Maintenance mode light                   | KK. FaST switch                         |
| R. Recovery tank full light                 | LL. FaST solution flow switch           |
| S. Clogged filter light                     |   |
| T. Hopper temperature light - Thermo Sentry |   |

10950

## OPERATION OF CONTROLS

### DIRECTIONAL PEDAL

The directional pedal controls direction of travel and the propelling speed of the machine. You change the speed of the machine with the pressure of your foot; the harder you press the faster the machine travels.

Forward: Press the top of the directional pedal with the toe of your foot.

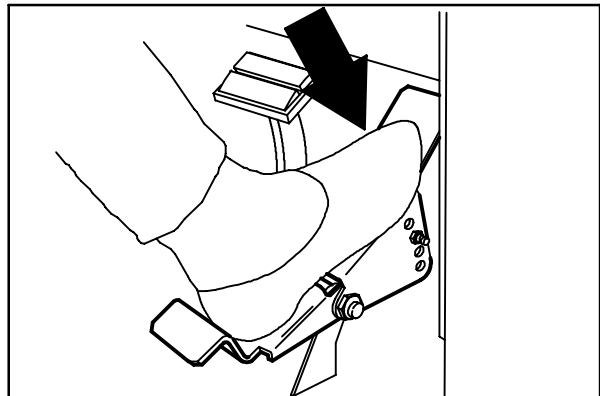

07790

Reverse: Press the bottom of the directional pedal with the heel of your foot.

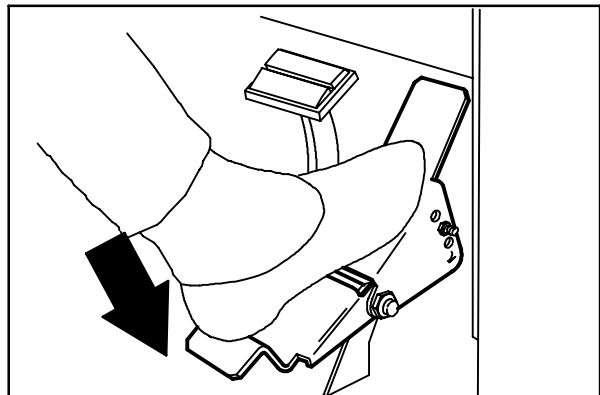

07791

Neutral: Take your foot off the directional pedal and it will return to the neutral position.

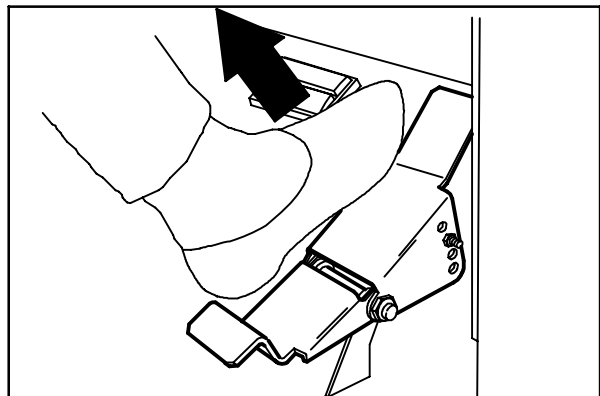

07792

**BRAKE PEDAL**

The brake pedal stops the machine.

**Stop:** Take your foot off the directional pedal and let it return to the neutral position. Step on the brake pedal.

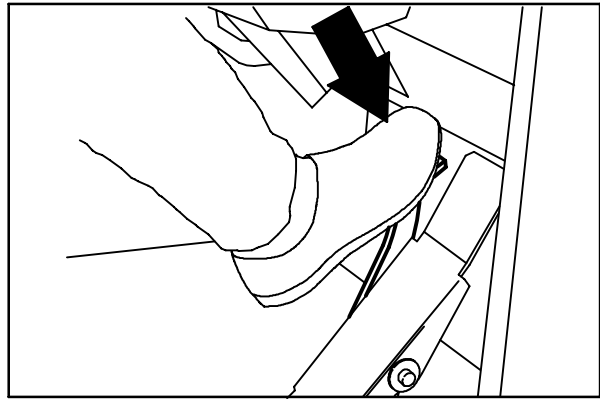

07754

**PARKING BRAKE PEDAL**

The parking brake pedal sets and releases the rear wheel brakes.

**Set:** Press on the brake pedal as far as possible, then press on the parking brake pedal with the toe portion of your foot to lock the parking brake pedal in place.

**FOR SAFETY: Before leaving or servicing machine; stop on level surface, set parking brake, turn off machine and remove key.**

**Release:** Press on the brake pedal to unlock the parking brake pedal.

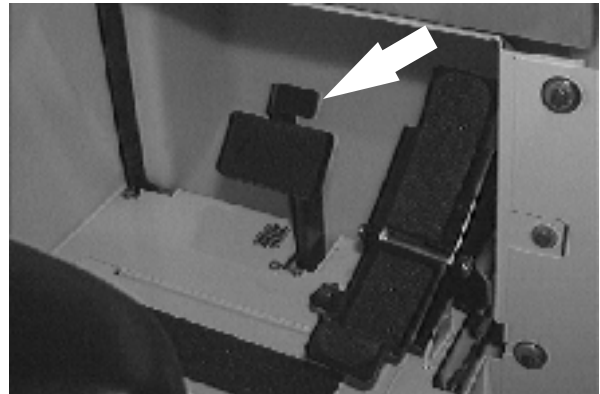
**HAZARD LIGHT SWITCH (OPTION)**

The hazard light switch powers on and off the hazard light.

**On:** Press the hazard light switch. The indicator light above the switch will come on.

**Off:** Press the hazard light switch. The indicator light above the switch will go off.

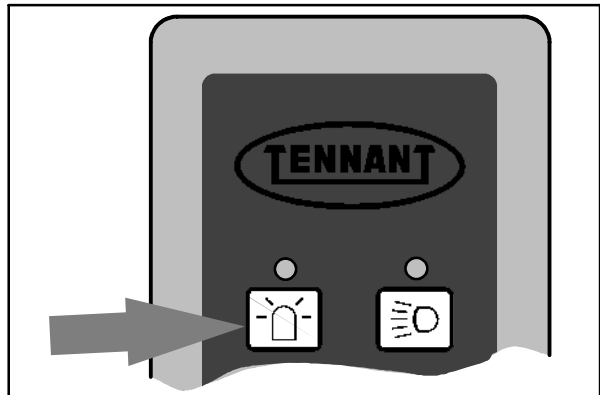

09293

## OPERATION

### OPERATING LIGHTS SWITCH

The operating lights switch powers on and off the headlights and taillights.

On: Press the operating lights switch. The indicator light above the switch will come on.

Off: Press the operating lights switch. The indicator light above the switch will go off.

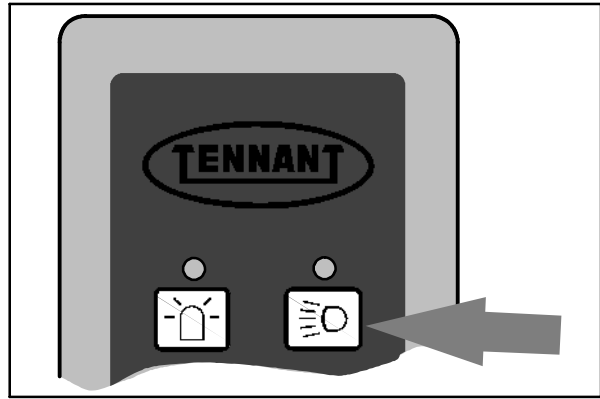

09292

### FILTER SHAKER SWITCH

The filter shaker switch starts the hopper dust filter shaker. The shaker automatically operates for 40 seconds.

Start: Press the filter shaker switch. The indicator light will remain on while the filter shaker is operating.

*NOTE: The filter shaker will operate automatically for a short time when the sweeping operations are stopped. The filter shaker will not operate while the sweeping or vacuum system is operating.*

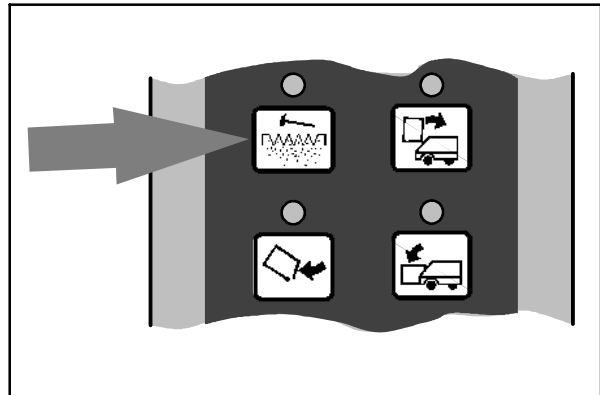

09294

### HOPPER RAISE SWITCH

The hopper raise switch raises the hopper.

Raise: Press and hold the hopper raise switch. The indicator light above the switch will come on.

Hold: Release the hopper raise switch.

**WARNING: Raised hopper may fall. engage hopper support bar.**

*NOTE: The main sweeping brush, side brush, and sweep vacuum fan will stop operating when the hopper is raised. If the sweep vacuum fan, side brush switch, or either of the main brush switches are pressed while the hopper is raised, the side brush will not start and the hopper raise switch indicator will blink.*

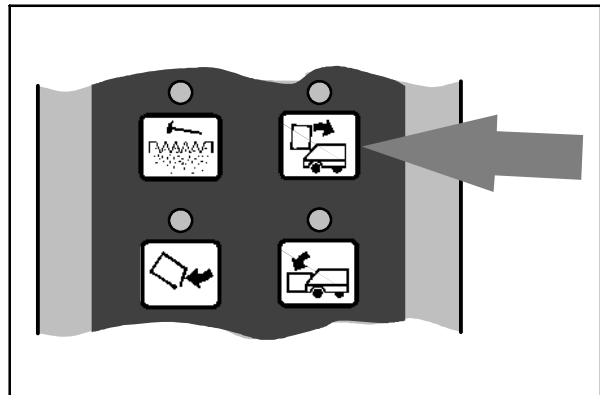

09295



### HOPPER DOOR SWITCH

The hopper door switch opens and closes the hopper door. Close the hopper door when emptying the hopper to control debris and dust.

**Open:** Press the switch. The indicator light above the switch will go out.

**Close:** Press the switch. The indicator light above the switch will come on.

*NOTE: The hopper door opens automatically when the main sweeping brush starts operating, and closes automatically when the machine is started or if the main sweeping brush is not operating.*

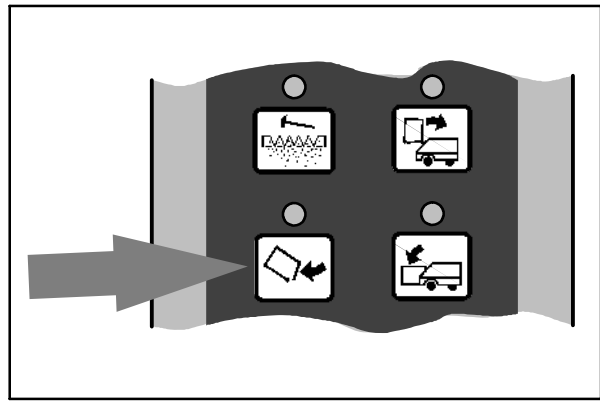

09542

### HOPPER LOWER SWITCH

The hopper lower switch lowers the hopper.

**Lower:** Press and hold the hopper lower switch. The indicator light above the switch will come on.

**Hold:** Release the hopper lower switch.

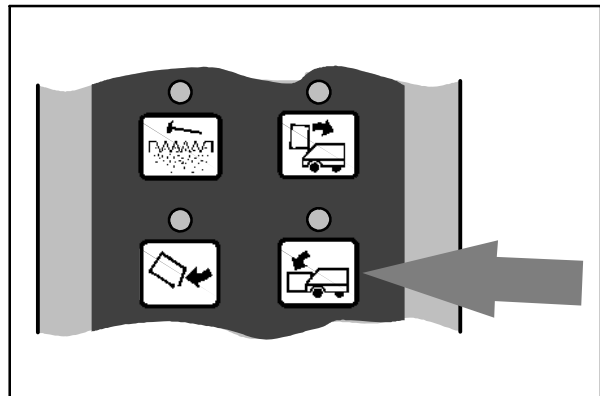

09543

### SIDE BRUSH SWITCH

The side brush switch controls the side brush position and rotation. The main sweeping brush must be operating for the side brush to work.

**Down and On:** Press the switch. The indicator light above the switch will come on.

**Up and Off:** Press the switch again. The indicator light above the switch will go off.

*NOTE: The side brush operates automatically when the main sweeping brush starts operating, if the side brush switch is on.*

*NOTE: The side brush will not start if the hopper is raised. If the side brush switch is pressed while the hopper is raised, the side brush will not start and the hopper raise switch indicator will blink.*

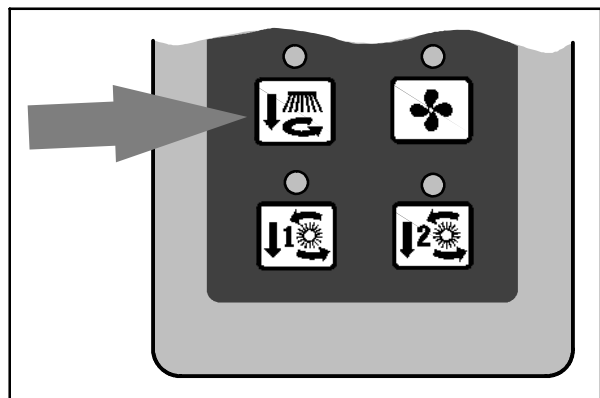

09544

## OPERATION

### SWEEP VACUUM FAN SWITCH

The sweep vacuum fan switch starts and stops the sweep vacuum fan. Do not operate the vacuum fan when sweeping in wet conditions.

**Start:** Press the switch. The indicator light above the switch will come on.

**Stop:** Press the switch. The indicator light above the switch will go off.

*NOTE: The sweep vacuum fan operates automatically when the main sweeping brush starts operating. The sweep vacuum fan will not turn on unless the main sweeping brush is operating.*

*NOTE: The sweep vacuum fan will not start if the hopper is raised. If the sweep vacuum fan switch is pressed while the hopper is raised, the sweep vacuum will not start and the hopper raise switch indicator will blink.*

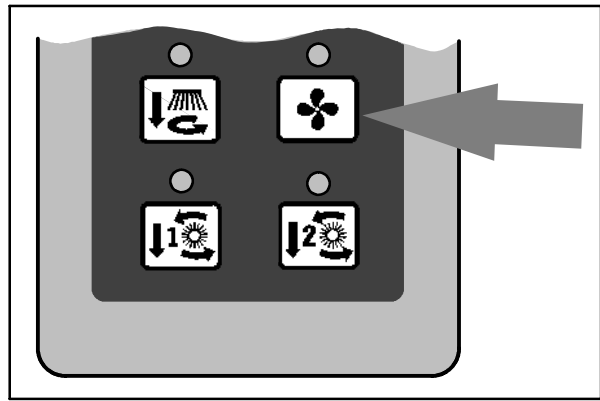

09545

### MAIN SWEEP BRUSH SPEED 1 SWITCH

The main sweep brush speed 1 switch controls the sweeping operation in normal speed.

The normal sweeping operations include the following. The hopper door will open, the sweep vacuum fan will come on, the side brush will lower and start, and the engine speed will increase to (Fast), and the main sweep brush will lower and operate at normal speed. Speed 1 is used for general sweeping.

**Down and on:** Press the switch. The indicator light above the switch will come on.

**Up and off:** Press the switch again. The indicator light above the switch will go off.

*NOTE: The normal sweeping operations will not start if the hopper is raised. If the main brush normal speed switch is pressed while the hopper is raised, the sweeping operations will not start and the hopper raise switch indicator will blink.*

*NOTE: Always raise the main brush when the machine is not being operated for some time. This prevents the main brush from getting a flat spot.*

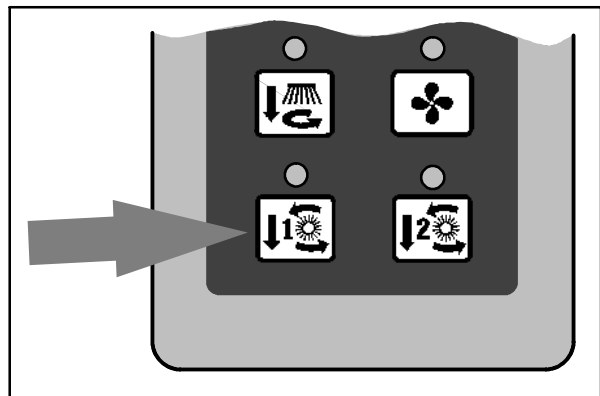

09546

### MAIN SWEEP BRUSH SPEED 2 SWITCH

The main brush speed 2 switch controls the sweeping operation in litter speed.

The litter sweeping operations include the following. The hopper door will open, the sweep vacuum fan will come on, the side brush will lower and start, and the engine speed will increase to (Fast), and the main sweep brush will lower and operate at speed 2. Speed 2 is used for sweeping light litter.

**Down and on:** Press the switch. The indicator light above the switch will come on.

**Up and off:** Press the switch again. The indicator light above the switch will go off.

*NOTE: The litter sweeping operations will not start if the hopper is raised. If the main sweep brush speed 2 switch is pressed while the hopper is raised, the sweeping operations will not start and the hopper raise switch indicator will blink.*

*NOTE: The main sweep brush Speed 2 switch can not be operated while scrubbing. If the main sweep brush is operating in speed 2 when the scrubbing operations are started, the machine will automatically change to main sweep brush to speed 1.*

*NOTE: Always raise the main brush when the machine is not being operated for some time. This prevents the main brush from getting a flat spot.*

### CHARGING SYSTEM LIGHT

The charging system light comes on when the alternator is not operating within normal range; 13.5 to 14.5 Volts. Stop operating the machine. Locate the problem and have it corrected.

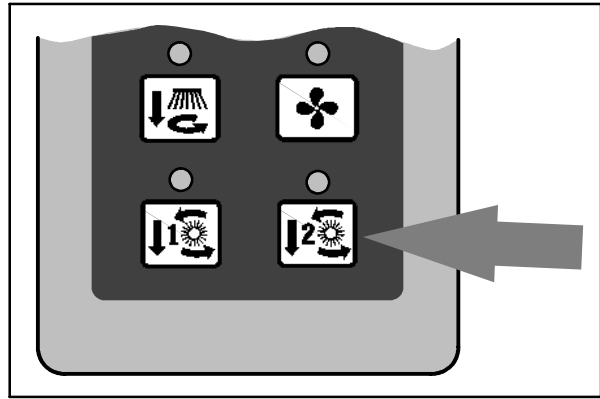

09558

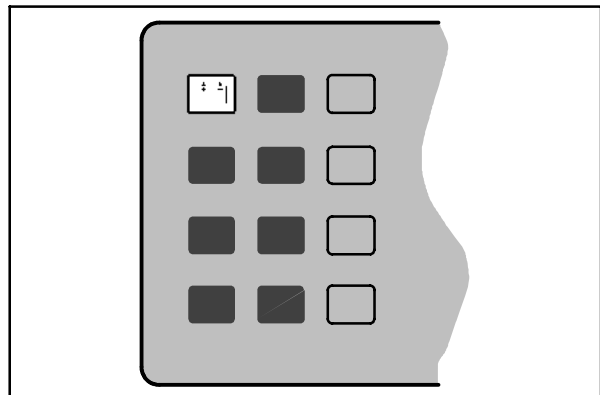

10642

## OPERATION

### ENGINE OIL PRESSURE LIGHT

The engine oil pressure light comes on when the engine oil pressure falls below 40 kPa (5 psi). Stop operating the machine. Locate the problem and have it corrected.

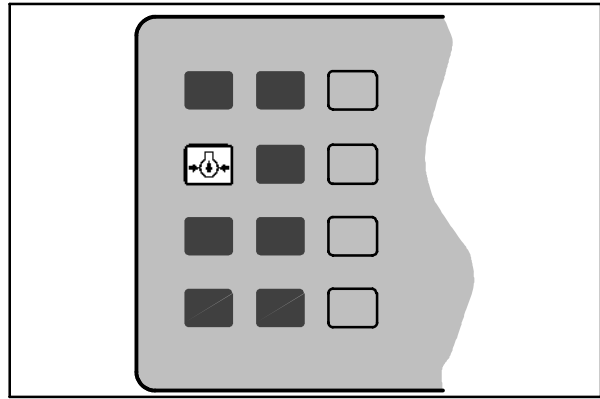

10643

### ENGINE WATER TEMPERATURE LIGHT

The engine water temperature light comes on when the temperature of the engine coolant is more than 107° C (225° F). Stop operating the machine. Locate the problem and have it corrected.

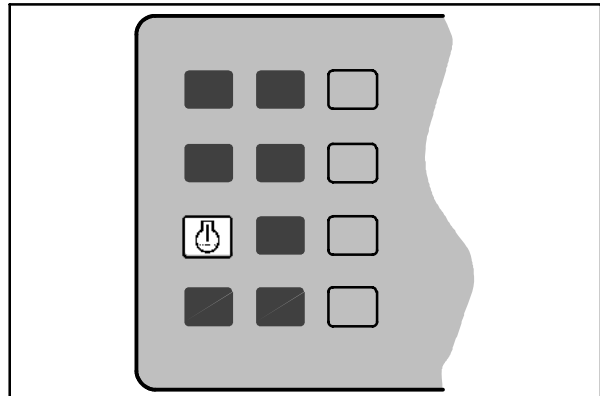

10644

### MAINTENANCE MODE LIGHT

The maintenance mode light comes on when the control panel diagnostic mode is manually activated. The maintenance mode is for service personnel use only. To clear the diagnostic mode, turn the ignition key off.

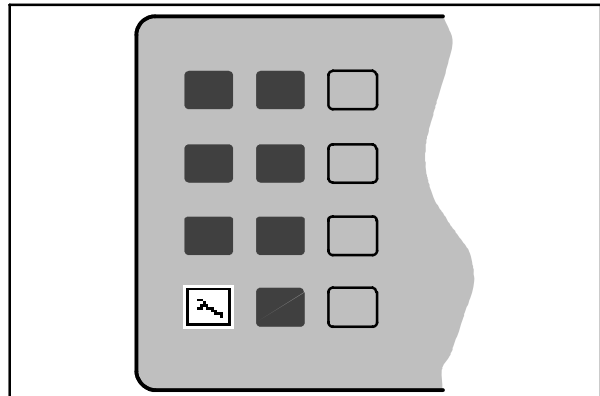

10645

### RECOVERY TANK FULL LIGHT

The recovery tank full light starts blinking when the recovery tank is full. The light will blink for 50 seconds and then stays on. Then the scrubbing operations will shut off.

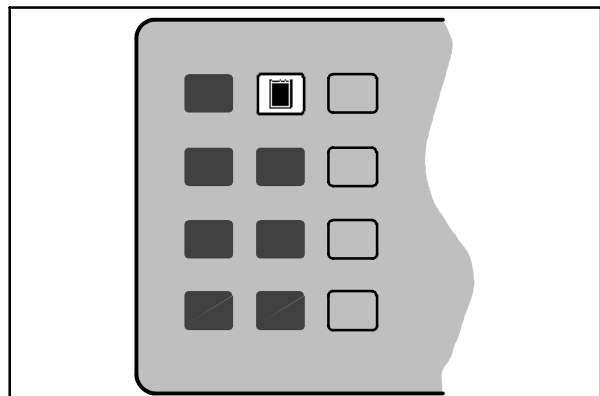

10886

**CLOGGED FILTER LIGHT**

The clogged filter light comes on when the hopper dust filter is clogged.

To clean the filter, press the filter shaker switch. If the clogged filter light remains lit, manually clean the hopper dust filter. See *HOPPER DUST FILTER* in *MAINTENANCE*.

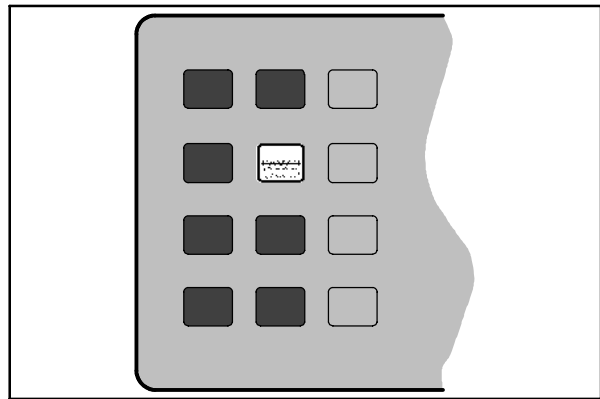

11115

**HOPPER TEMPERATURE LIGHT - THERMO SENTRY**

The hopper temperature light comes on when there is too much heat in the hopper, possibly from a fire. The Thermo Sentry will stop the sweeping vacuum fan. Stop operating the machine. Locate the problem and have it corrected.

The Thermo Sentry has to be reset manually, see *THERMO SENTRY* in *MAINTENANCE*.

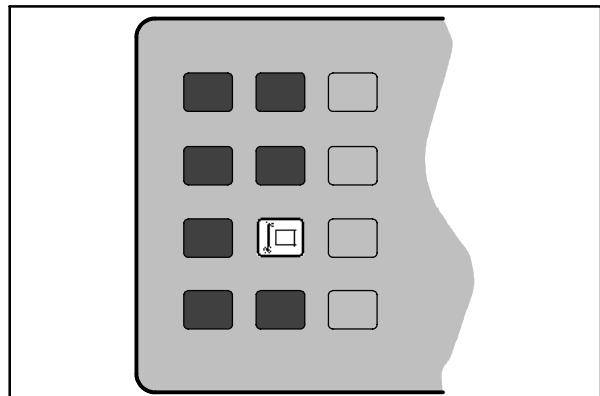

11116

**OK LIGHT**

The OK light comes on after the two control panels have run through and passed a self-check every time the machine is started. The OK light will go out when the scrub or squeegee switch is activated, or the engine speed is changed to (Fast).

The OK light blinks when the main control panel has passed the self-check, but the side control panel has not passed the self-check. The OK light does not come on at all, when the machine is started, if the main control panel does not pass the self-check.

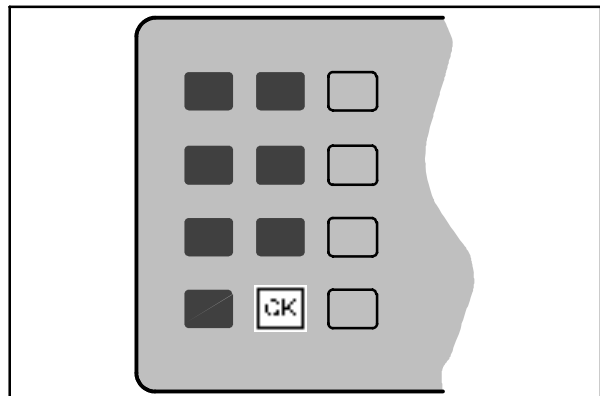

10889

## OPERATION

### FUEL LEVEL GAUGE

The fuel level gauge indicates how much fuel is in the fuel tank with a segmented LED light.

When the tank is full, all ten of the LED segments are lit. As the fuel tank empties, the LED segments shut off. The fuel tank is empty when the last LED segment blinks.

*NOTE: Do not let the fuel tank empty completely. Air can enter the fuel system and it will need bleeding before the next engine start.*

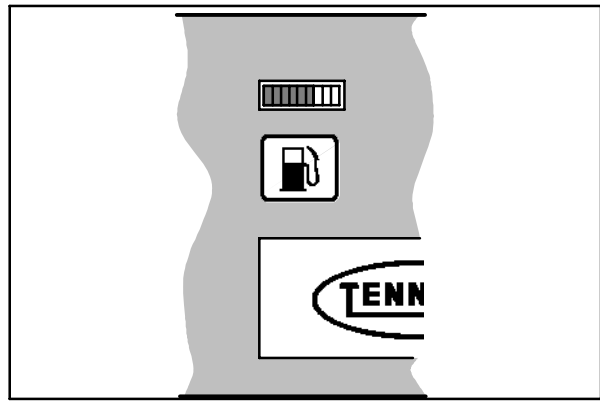

07764

### HOURMETER

The hourmeter records the number of hours the machine has been operated. The hourmeter displays the number of hours in tenths of an hour. Use this information to determine machine maintenance intervals.

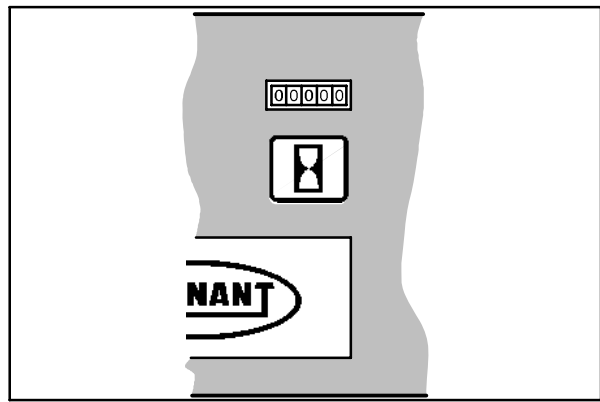

07765

### ES SWITCH (OPTION)

The ES switch turns on and off the extended scrub system. When the machine is started, the ES switch will default to the last setting used.

**On:** Press the ES switch. The indicator light above the switch will come on.

**Off:** Press the ES switch. The indicator light above the switch goes off.

*NOTE: When the ES switch is on and the water levels in the tanks are at the proper levels, there will be a slight delay before the ES pump turns on.*

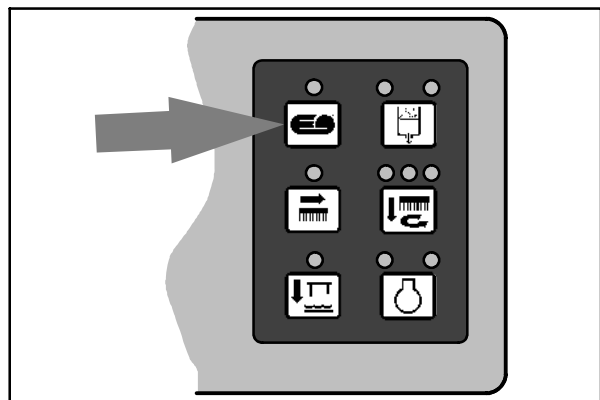

10951

**DETERGENT FLOW SWITCH (OPTION)**

The detergent flow switch starts and stops the detergent pump for the optional ES system. When the machine is started, the detergent flow switch will default to the last setting used.

**Start at one-half flow:** Press the detergent flow switch. The left indicator light above the switch will come on.

**Increase to full flow:** Press and hold the detergent flow switch until both indicator lights above the switch come on.

**Stop:** Press the detergent flow switch. Both indicator lights are off.

*NOTE: The detergent will turn on when the scrubbing operations are started.*

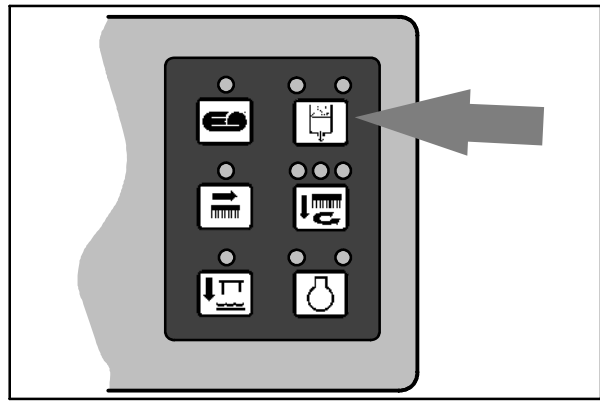

11106

**EDGE SCRUB SWITCH**

The edge scrub switch extends the scrub head to the right to allow close edge scrubbing.

**Out:** Press the edge scrub switch during scrubbing. The indicator light above the switch will come on.

**In:** Press the edge scrub switch. The indicator light above the switch goes off.

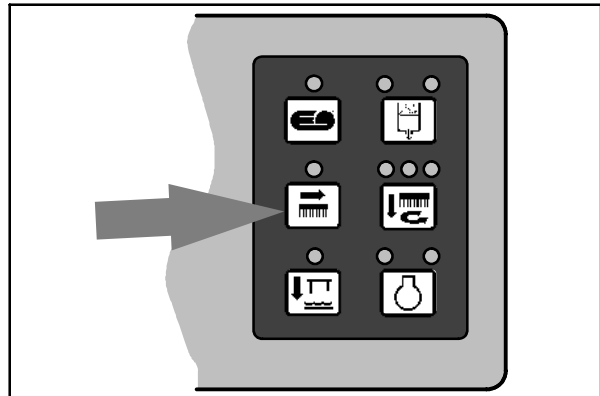

11104

## OPERATION

### SCRUB SWITCH

The scrub switch controls the scrubbing operations. The scrub switch also sets the scrub brush pressure.

The scrubbing operations include the following. The scrub head lowers and the scrub brushes turn on. The scrub head will move into the edge scrub position if the edge scrub switch is on. The rear squeegee will lower and the vacuum fan will start. The solution system will start, if the solution flow switch is on. The FaST system or optional ES system and detergent pump will start, if the switches are on. The engine speed will change to (Fast).

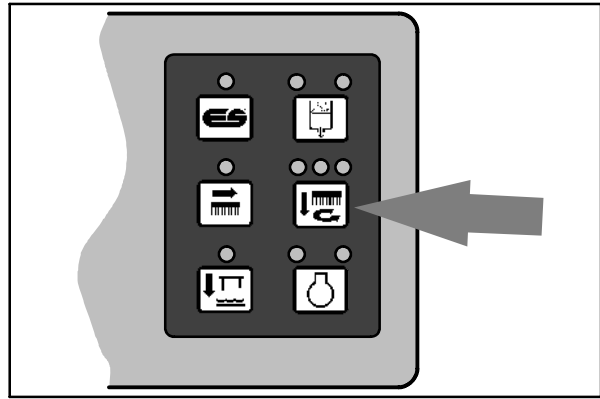

11107

**Start:** Press the scrub switch. The indicator light above the switch will come on.

**Stop:** Press the scrub switch. The indicator light above the switch goes off.

**Scrub brush pressure:** Press and hold the scrub switch. The brush pressure will scroll through the three settings. The pressure setting selected when the switch is released, will be the new default brush pressure setting.

The brush pressure has three positions. Under normal conditions, the brush pressure should be set in the minimum setting. Under heavy grime conditions, the brush pressure should be set in the maximum setting. Travel speed and floor conditions will affect the scrubbing performance.

*NOTE: The brush pressure setting, The FaST system, the edge scrub, and the detergent flow rate will default to the last setting used, when the scrubbing operations are started again.*

*NOTE: If the main sweep speed 2 is operating when the scrubbing operations are started, the machine will automatically change to main sweep brush speed 1.*

*NOTE: The scrub head will raise when the machine travels in reverse.*



## SQUEEGEE SWITCH

The squeegee switch controls the position of the rear squeegee, and starts and stops the scrubbing vacuum fan. The rear squeegee can be operated separately, from the scrub brushes, for water pick-up.

**Lower and start:** Press the squeegee switch. The indicator light above the switch will come on.

**Raise and stop:** Press the squeegee switch. The indicator light above the switch goes off. There will be a slight delay before the vacuum shuts off.

*NOTE: The rear squeegee lowers and scrubbing vacuum starts automatically when the scrubbing operations start.*

*NOTE: The rear squeegee will raise and the scrubbing vacuum will shut off after a short delay when the machine travels in reverse.*

*NOTE: The rear squeegee will raise and the scrubbing vacuum fan will shut off after a short delay when the scrubbing operations are shut off.*

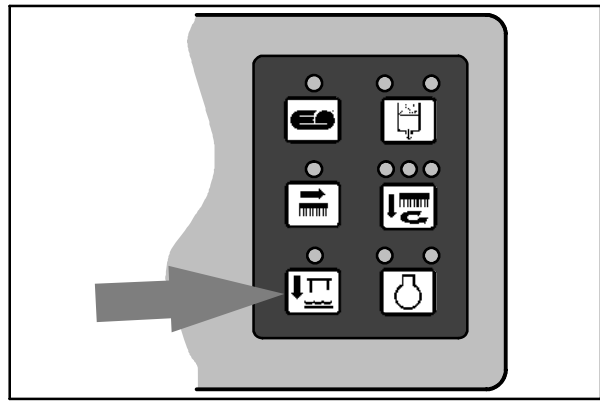

11105

## THROTTLE LEVER

The throttle lever controls the engine speed.

**Fast:** Push the lever into the **Fast** position.

**Idle:** Move the lever into the **Idle** position.

**Off:** Pull the lever into the **Off** position.

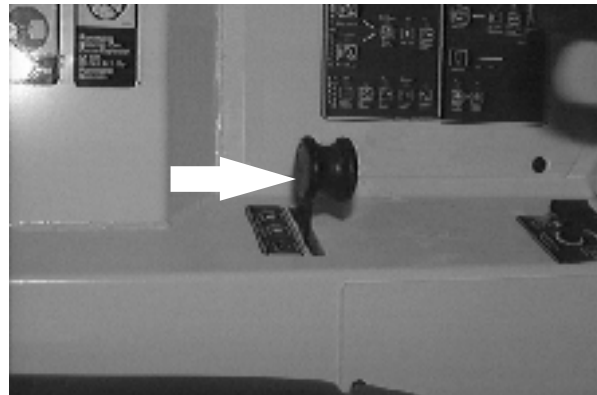

## OPERATION

### STEERING WHEEL

The steering wheel controls the machine's direction. The machine is very responsive to the steering wheel movements.

Left: Turn the steering wheel to the left.

Right: Turn the steering wheel to the right.

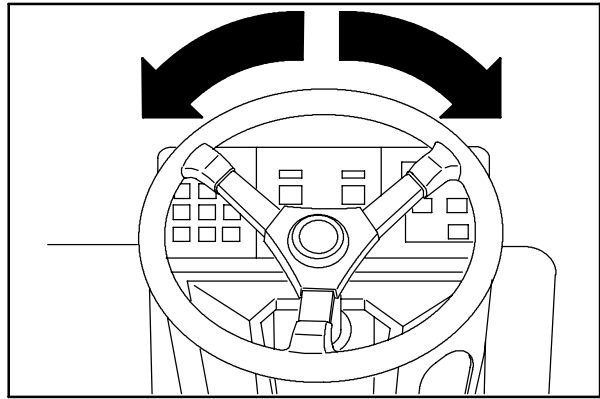

07801

### HORN BUTTON

The horn button operates the horn.

Sound: Press the button.

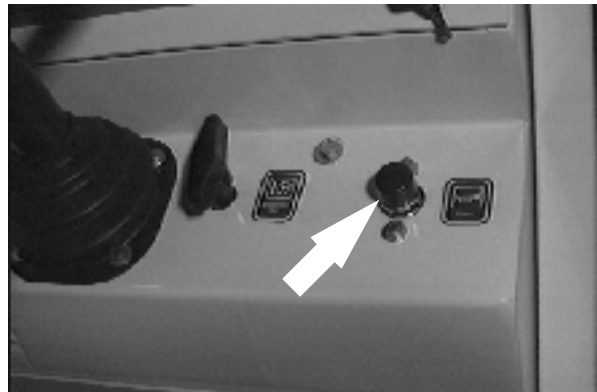

### IGNITION SWITCH

The ignition switch starts and stops the engine with a key.

**FOR SAFETY: When starting machine, keep foot on brake and directional pedal in neutral.**

Preheat: Turn the key all the way counter-clockwise and hold it there for 5 to 15 seconds, depending on the weather conditions.

Start: Turn the key all the way clockwise. Release the key as soon as the engine starts.

Stop: Turn the key counter-clockwise.

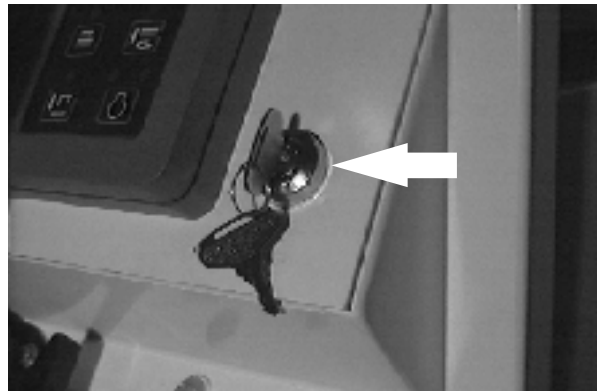

**TURN SIGNAL SWITCH (OPTION)**

The turn signal switch operates the turn signals.

Right: Push the switch lever forward.

Left: Pull the switch lever back.

Flashers: Pull out the knob.

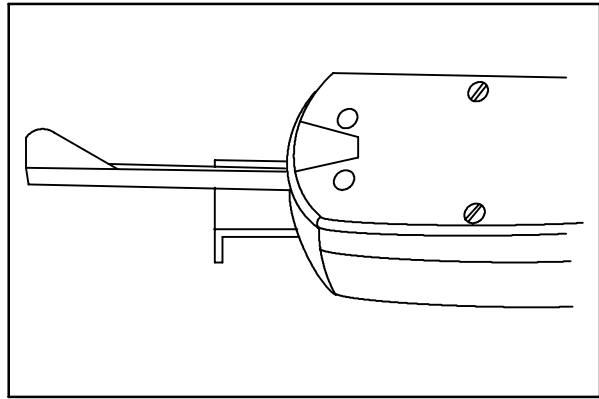

06745

**STEERING COLUMN TILT HANDLE**

The steering wheel tilt handle controls the angle of the steering wheel.

Adjust: Pull out the tilt handle, move the wheel up or down, and release the tilt handle.

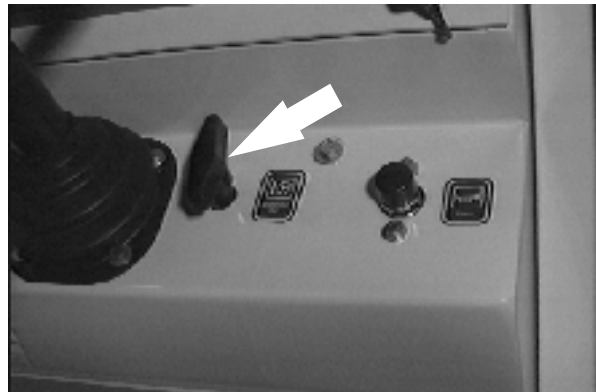

# OPERATION

## CIRCUIT BREAKERS

The circuit breakers are resettable electrical circuit protection devices. Their design stops the flow of current in the event of a circuit overload. Once a circuit breaker is tripped, it must be reset manually. Press the reset button after the breaker has cooled down.

If the overload that caused the circuit breaker to trip is still there, the circuit breaker will continue to stop current flow until the problem is corrected.

The circuit breakers are located in the operator compartment.

The chart lists the circuit breakers and the electrical components they protect.



<b>Circuit Breaker</b>	<b>Rating</b>	<b>Circuit Protected</b>
CB-1	15 A	Horn
CB-2	15 A	Ignition
CB-3	10 A	Instrument panel
CB-4	15 A	Scrubbing
CB-5	15 A	Filter shaker, vacuum fan
CB-6	15 A	Operating lights
CB-7	15 A	ES
CB-8	15 A	Sweeping
CB-9	15 A	Solenoid valve

### MAIN SWEEP BRUSH DOWN PRESSURE KNOB

The main sweep brush down pressure knob changes the amount of contact the main sweep brush has with the sweeping surface.

Heavy: Turn the main sweep brush down pressure knob counter-clockwise.

Light: Turn the main sweep brush down pressure knob clockwise.

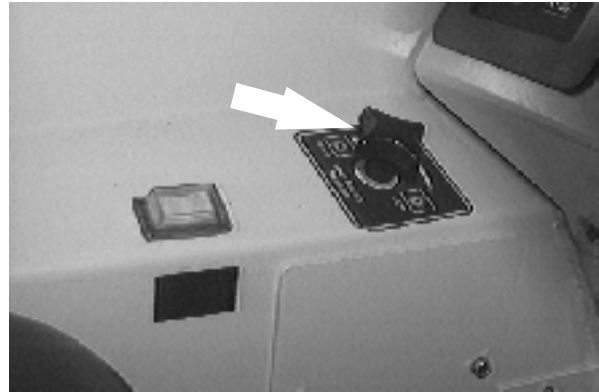

### SIDE BRUSH DOWN PRESSURE KNOB

The side brush down pressure knob changes the side brush contact with the sweeping surface.

Heavy: Turn the side brush down pressure knob counter-clockwise.

Light: Turn the side brush down pressure knob clockwise.



### SOLUTION FLOW SWITCH (WITHOUT FaST)

The solution flow switch controls the flow of solution to the floor. The solution flow switch is only on machines without the FaST system.

Start (1): Place the solution flow switch in the middle position. Use this flow rate for smooth floors and light dirt.

Increase (2): Press the right of the solution flow switch. Use this flow rate for rough floors and heavy or compacted dirt.

Stop (0): Press the left of the solution flow switch.

**NOTE:** The solution flow starts, if the solution flow switch is on, when the scrubbing operations start.

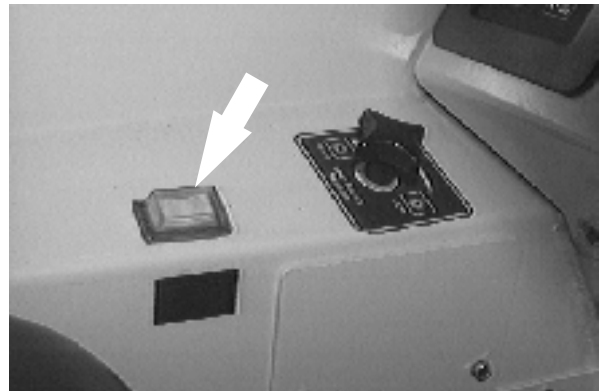

## OPERATION

### SOLUTION FLOW SWITCH (FaST)

The FaST solution flow switch enables the FaST (Foam Scrubbing Technology) system. When the FaST system is enabled, it is turned on and off with the FaST switch. Disable the FaST system before using the machine for conventional scrubbing.

For machines with the FaST system, the FaST solution flow switch controls the flow of solution to the floor.

Start (1): Place the FaST solution flow switch in the middle position. Use this flow rate for smooth floors and light dirt.

Increase (2): Press the top of the FaST solution flow switch. Use this flow rate for rough floors and heavy or compacted dirt.

Stop (0): Press the bottom of the FaST solution flow switch.

### FaST SWITCH

The FaST switch enables the FaST (Foam Scrubbing Technology) system. When the FaST system is enabled, it is turned on and off with the FaST switch. Disable the FaST system before using the machine for conventional scrubbing.

Disable FaST for conventional scrubbing: Press the bottom of switch to the **FaST system off** position.

Enable the FaST system: Press the top of switch to the **FaST system on** position.

*NOTE: The FaST system will not start until the directional pedal is pressed.*

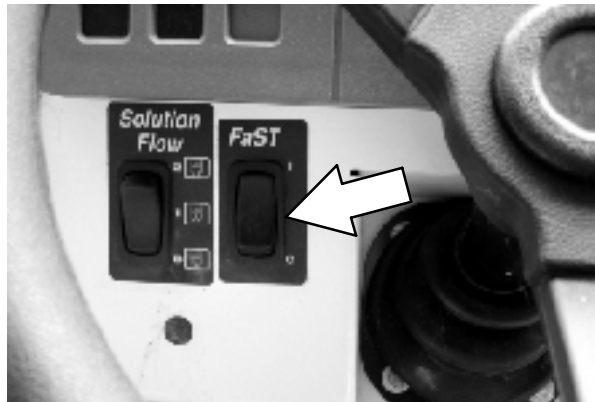
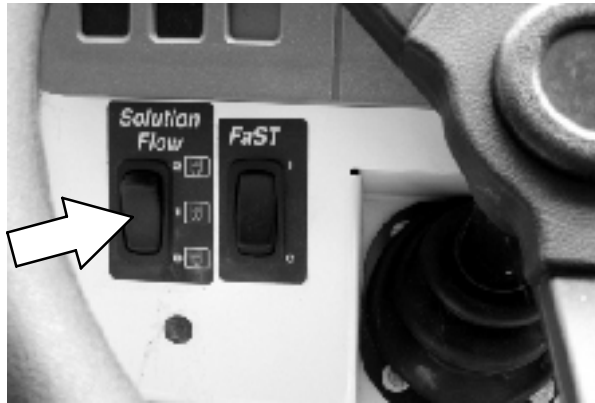

**LATCHES**

The side doors and recovery tank cover are secured with latches.

Open the main brush side doors: Push down on the door latch.

Open the engine side door: Push in the door latch.

Open the recovery tank cover: Pull up on the latch.

Open the radiator grill: Lift and turn the latch.

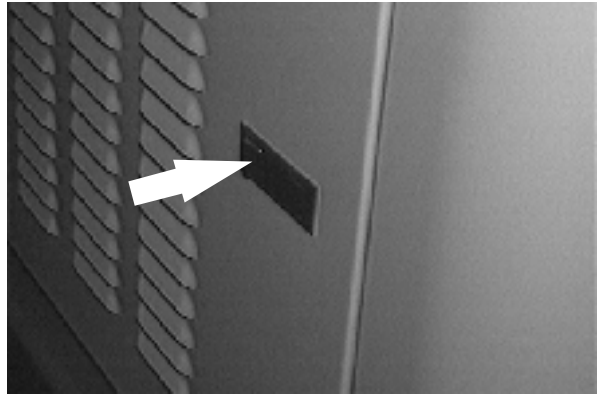

**FUSE**

Fuses are a one-time protection device designed to stop the flow of current in the event of a circuit overload. Never substitute higher value fuses than specified.

The fuse is located in the operator compartment. Remove the circuit breaker panel to gain access to the fuse.

Fuse	Rating	Circuit Protected
FU-1	40 A	Glow plugs

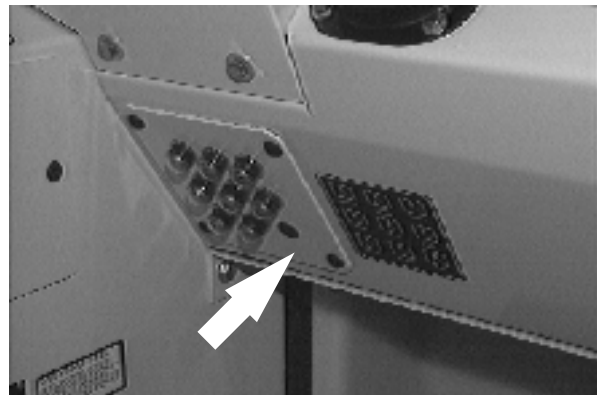

## OPERATION

### OPERATOR SEAT

The operator seat is a fixed back style with a forward-backward adjustment.

Adjust: Pull the lever out, slide the seat backward or forward to the desired position and release the lever.

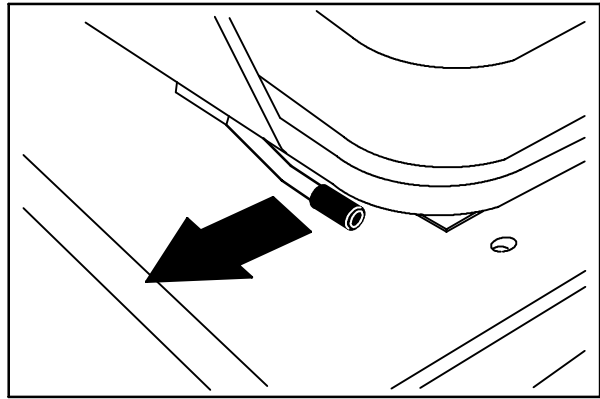

07797

Lift: Pull up on the seat mounting plate until the seat mount locks up.

Lower: Pull on the release lever and lower the seat mounting plate.

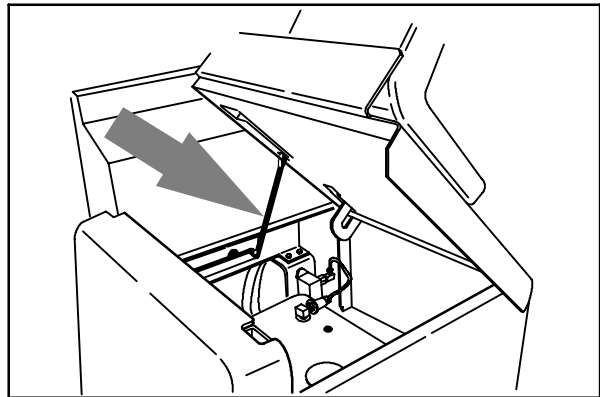

08052

### HOPPER SUPPORT BAR

The hopper support bar is located on the operator's side of the hopper. The hopper support bar holds the hopper in the raised position to allow work under the hopper. **DO NOT** rely on the machine hydraulic system to keep the hopper raised.



**WARNING: Raised hopper may fall.  
Engage hopper support bar.**

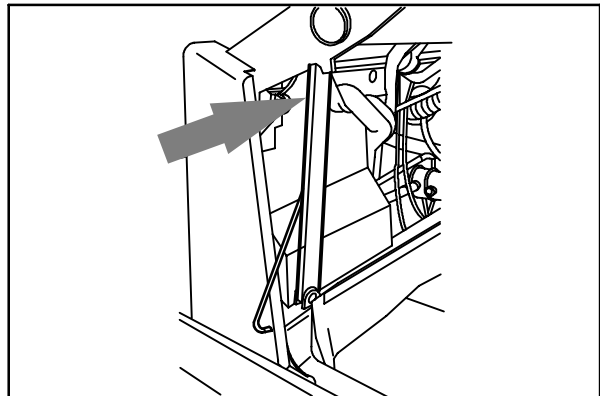

07803



---

## HOW THE MACHINE WORKS

---

The steering wheel controls the direction of machine travel. The directional pedal controls the speed and forward/reverse direction. The brake pedal slows and stops the machine.

The side brush sweeps debris into the path of the main sweeping brush. The main brush sweeps debris from the floor into the hopper. The vacuum system pulls dust and air through the hopper and the hopper dust filter.

Water and detergent from the solution tank flow to the floor through a solution valve to the scrub brushes. The brushes scrub the floor. As the machine is moved forward the squeegee wipes the dirty solution off the floor, which is then picked up and drawn into the recovery tank.

When using the ES mode, the dirty solution in the recovery tank is filtered and returned to the solution tank to be reused.

When sweeping and scrubbing is finished, clean the hopper dust filter, empty the hopper, and drain and clean the recovery tank. If using the ES system, drain and clean the solution tank, and clean the ES filter.

## OPERATION

### FaST SCRUBBING SYSTEM

Unlike conventional scrubbing, the FaST (Foam Scrubbing Technology) system operates by injecting the FaST PAK concentrate agent into the system with a small amount of water and compressed air. This mixture creates a large volume of expanded wet foam.

The expanded foam mixture is then dispersed onto the floor while the machine is scrubbing. When the squeegee picks up the mixture, the patented foaming agent has collapsed and is recovered into the recovery tank.

The FaST system can be used with all double scrubbing and heavy duty scrubbing applications.

Using the FaST system can increase productivity by 30% by reducing your dump/fill cycle. It will also reduce chemical usage and storage space. One FaST PAK of concentrated agent can scrub up to 1 million sq. ft.

*NOTE: Do not enable the FaST system with conventional cleaning detergents in the solution tank. Drain, rinse and refill the solution tank with clear cool water only before operating the FaST system. Conventional cleaning detergents/restorers may cause failure to the FaST solution system.*

*NOTE: Storage or transporting machines equipped with FaST in freezing temperatures requires special procedures. Check with a TENNANT representative for advice.*

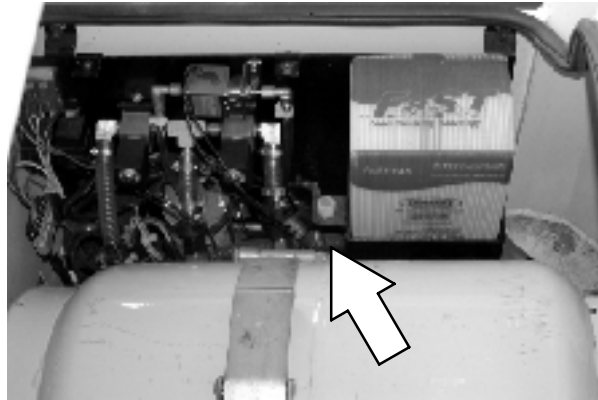

**FaST**  
Foam Scrubbing Technology

***The safe scrubbing alternative***

---

**PRE-OPERATION CHECKLIST**

---

- Check under the machine for leaks (fuel, oil, coolant, scrubbing solution).
- Check the engine air filter indicator.
- Check the engine oil level.
- Check fuel level.
- Check the brakes and steering for proper operation.
- Check the rear squeegee for wear and proper deflection. Check the side squeegees for wear.
- Check for wire, string, or twine wrapped around the sweeping and scrub brushes.
- Check the vacuum hoses for debris or obstructions.
- ES machines. Check that the ES filter and solution outlet filter is clean.
- Check for loose fittings, or wires.
- Check the condition of the v-belt.
- Check the hydraulic oil level.
- Check the cooling system level.
- ES machines. Check detergent level in the detergent tank, fill as required.
- FAST Scrubbing: Check the FaST PAK concentrate agent level, replace carton as needed. See the INSTALLING THE FaST PAK AGENT section of the manual.
- FAST Scrubbing: Check that all conventional cleaning agents/restorers are drained and rinsed from the solution tank.
- FAST Scrubbing: Check that the solution tank is filled with **clear cool water only**.

### INSTALLING FaST PAK AGENT

*NOTE: Machine must be equipped with FaST before the FaST PAK agent can be installed.*

1. Remove the perforated knock-outs from the FaST PAK Floor Cleaning Concentrate carton. Do not remove the bag from the carton. Pull out the bag's hose connector on the bottom of the bag and remove the hose cap from the connector.

***NOTE: The FaST PAK Floor Cleaning Concentrate is specifically designed for use with the FaST system scrubbing application. NEVER use a substitute, machine damage will result.***

**FOR SAFETY: When using machine, always follow the handling instructions on chemical container.**

2. Empty the solution tank. See the DRAINING AND CLEANING THE TANKS section of the manual.

*NOTE: When scrubbing with the FaST system option, use clean water only. Do not add cleaning agents in the solution tank. Conventional cleaning agents/restorers may cause failure to the FaST solution system..*

3. Raise the seat mounting plate to access the FaST PAK carton.

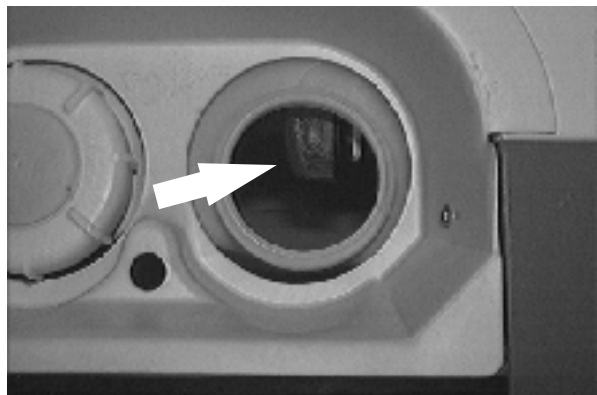
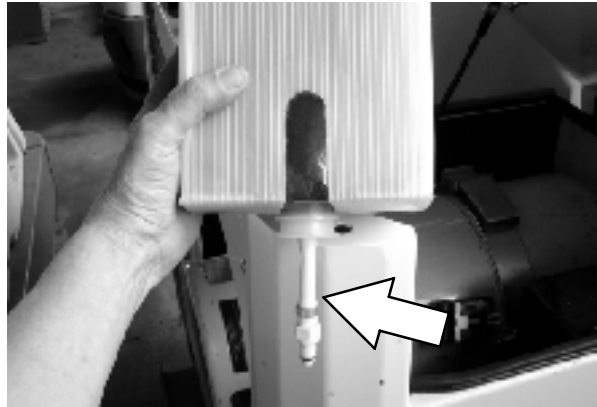

4. Connect the supply hose to the FaST PAK bag.

*NOTE: If any dried concentrate is visible on the supply hose connector or the on the FaST PAK connector, soak and clean with warm water.*

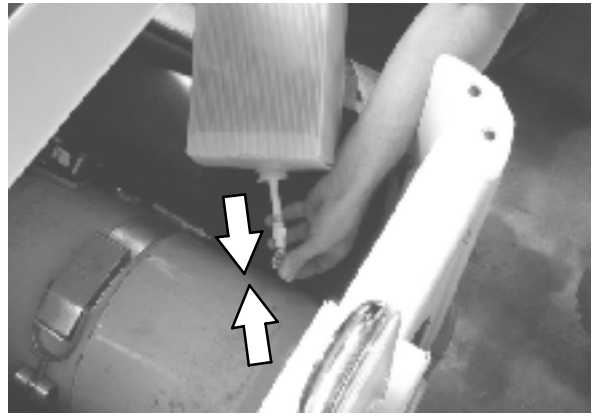

5. Place the FaST PAK carton in the carton holder under the seat mounting plate on the machine.

*NOTE: Make sure supply hose is not pinched.*



6. Make sure to connect the supply hose onto the hose storing plug when the supply hose is not connected to the FaST PAK. This will prevent the FaST solution system from drying out and clogging up the hose.

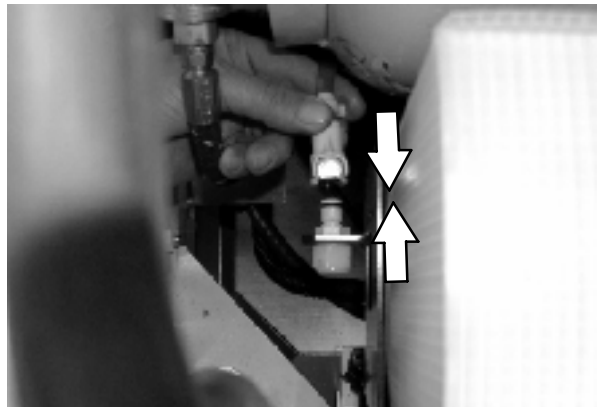

7. When replacing an empty FaST PAK carton, allow the new FaST PAK detergent to gravity feed into the system for several minutes prior to operating the FaST system. If the detergent does not flow out of the FaST PAK, simply squeeze and release the hose several times. If the previous FaST PAK was run dry, it may take up to 5-10 minutes of operation to remove any air pockets in the system before you achieve maximum foaming.

## STARTING THE MACHINE

8. You must be in the operator's seat with the directional pedal in neutral, and your foot on the brake pedal or with the parking brake set.

**FOR SAFETY: When starting machine, keep foot on brake and directional pedal in neutral.**

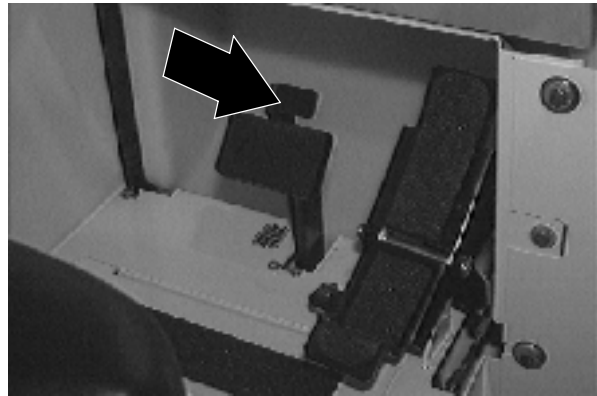

9. Move the throttle lever to the **idle** position.

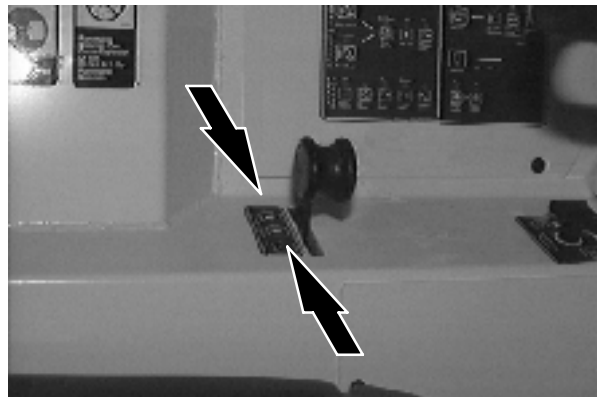

10. Turn the ignition switch key all the way counter-clockwise and hold it there for 5 to 15 seconds depending on the weather.

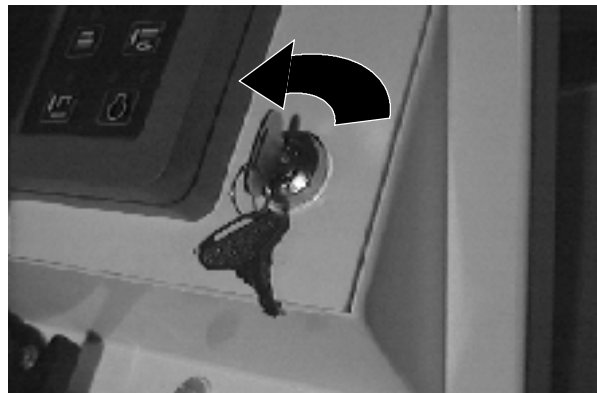

11. Turn the ignition switch key clockwise until the engine starts.

*NOTE: Do not operate the starter motor for more than 10 seconds at a time or after the engine has started. Allow the starter to cool between starting attempt or damage to the starter motor may occur.*

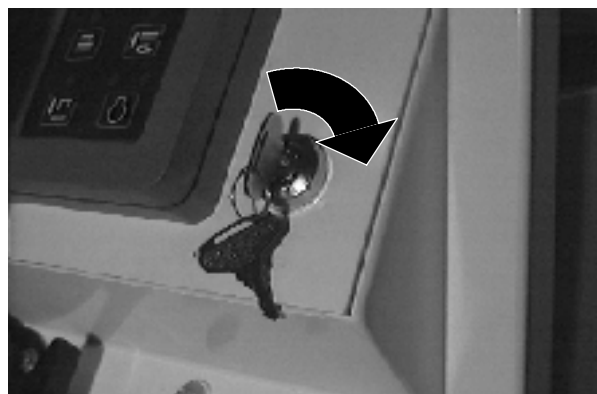

12. Allow the engine and hydraulic system to warm up three to five minutes.

**!** **WARNING: Engine emits toxic gases. Severe respiratory damage or asphyxiation can result. Provide adequate ventilation. Consult with your regulatory authorities for exposure limits. Keep engine properly tuned.**

13. Release the machine parking brake.

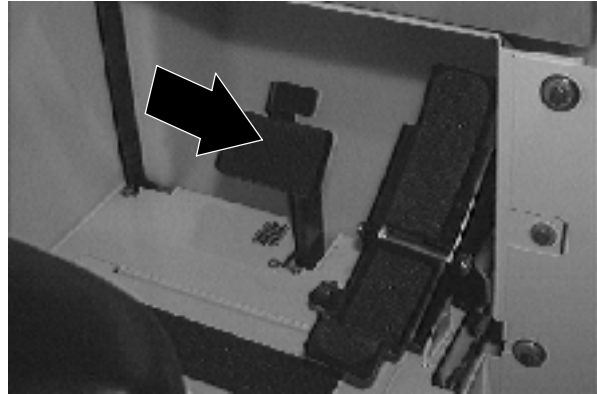

14. Move the throttle lever to the **fast** position.

15. Drive the machine to the area to be cleaned.

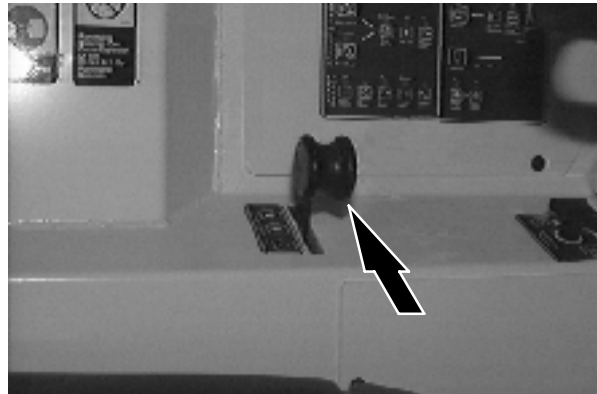

## SWEEPING, SCRUBBING, AND BRUSH INFORMATION

Pick up oversized debris before sweeping. Flatten or remove bulky cartons from aisles before sweeping. Pick up pieces of wire, twine, string, etc., which could become entangled in brush or brush plugs.

Plan the sweeping and scrubbing in advance. Try to arrange long runs with minimum stopping and starting. Sweep debris from very narrow aisles into main aisles ahead of time. Do an entire floor or section at one time. Drive as straight a path as possible. Avoid bumping into posts or scraping the sides of the machine. Overlap the brush paths.

Avoid turning the steering wheel too sharply when the machine is in motion. The machine is very responsive to the movement of the steering wheel. Avoid sudden turns, except in emergencies.

Adjust the machine speed, scrub brush pressure, and detergent and solution flow as required when scrubbing. Use minimum scrub brush pressure and solution flow required for the best scrubbing results. The machine has an edge clean feature for scrubbing against an edge.

When the recovery tank is almost full, the recovery tank full indicator will blink for almost a minute before the scrubbing system shuts off. The recovery tank will have to be drained and cleaned. Then refill the solution tank with clean water and detergent and continue cleaning.

For best results, use the correct brush type for your sweeping and scrubbing application. The following are recommendations for main sweeping, scrubbing, and side brush applications.

***Nylon 5-double and 8-double row main sweep brush*** – Recommended for general sweeping, and has good hopper loading. Nylon has the longest life of the bristle types. Use this brush for sweeping rough or irregular surfaces.

***Nylon 24-row main sweep brush*** – Recommended for severe dust conditions on rough surfaces. This brush has excellent pickup and long life.

***Polypropylene 8-double row main sweep brush*** – Superior pick-up of sand, gravel, and paper litter. Polypropylene retains its stiffness when wet, and can be used indoors or out with equal performance. Not recommended for high-temperature debris.

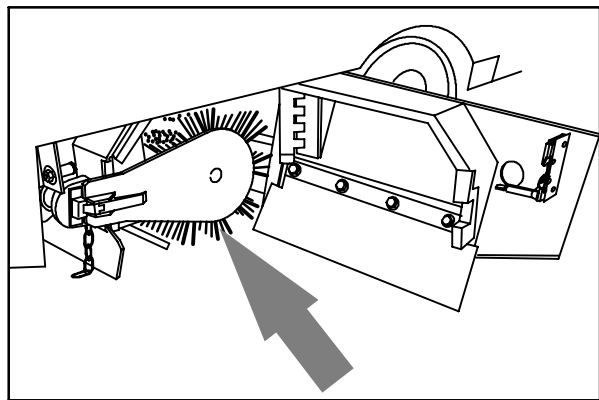

08002



**Polypropylene and Wire 8-double row main brush** – The wire bristles loosen slightly packed soilage and heavier debris. The polypropylene bristles sweep up the debris with excellent hopper loading.

**Fiber and Wire 24-row main sweep brush** – Offers good sweeping action and pickup in heavy dust concentrations. This brush is recommended where soilage is slightly encrusted. The brush is not recommended for heavy buildup or hard packed soilage.

**Wire 8-double row main sweep brush** – The stiff wire bristles cut through compacted grime, hard to sweep dirt, and dirt mixed with oil, grease, or mud. This brush is recommended for foundry sweeping where heat may melt synthetic bristles. This brush has good hopper loading ability, but is not recommended for dusty applications.

**Polypropylene side brush** – A good general purpose brush for sweeping of light to medium debris in both indoor and outdoor applications. This brush is recommended when bristles may get wet.

**Nylon side brush** – A longer life, general purpose brush that is recommended for rough surfaces.

**Flat wire side brush** – Recommended for outside and curb-side sweeping where soilage is heavy or compacted. The stiff wire bristles dig out soilage. This brush is also recommended for foundry sweeping where heat may melt synthetic bristles.

**Polypropylene scrub brush** – A general-purpose brush with stiff bristles for aggressive action on slightly compacted soilage. Works well on concrete, wood, and tile surfaces.

**Wire scrub brush** – This brush is the most aggressive. Recommended for soilage, heavy buildup and stripping rubber burns.

**Non-scuff polypropylene scrub brush** – This brush uses a softer, general purpose poly bristle to lift lightly compacted soilage, without scuffing high-gloss coated floors.

**Nylon scrub brush** – Recommended for scrubbing coated floors. Cleans without scuffing.

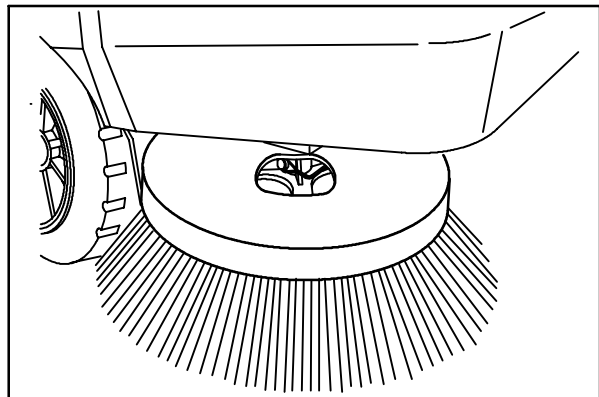

08046

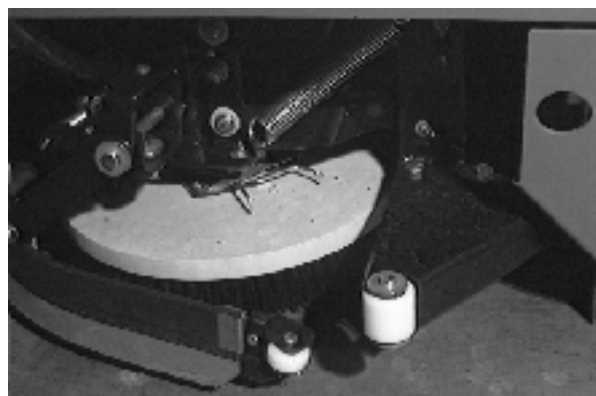

## OPERATION

---

**Super abrasive bristle scrub brush** – Nylon fiber impregnated with abrasive grit to remove stains and soilage. Strong action on any surface, performing well on buildup, grease, or rubber burns.

**Bassine scrub brush** – Traditional natural fiber is still preferred by many for general scrubbing on quarry tile, terrazzo, and marble.

**Stripping pad** – This pad is for stripping floors. Quickly and easily cuts through old finish to prepare the floor for recoating.

**Scrubbing pad** – This pad is for scrubbing floors. Removes dirt, spills and scuffs, leaving a clean surface ready for recoating.

**Buffing pad** – This pad is for buffing floors. Quickly cleans and removes scuff marks while polishing the floor to a high gloss.

**Polishing pad** – This pad is for polishing floors. Maintains a high gloss. Use to buff very soft finishes and lower traffic areas, or use for polishing soft waxes on wood floors.

---

## SWEEPING

---

1. Start the engine.

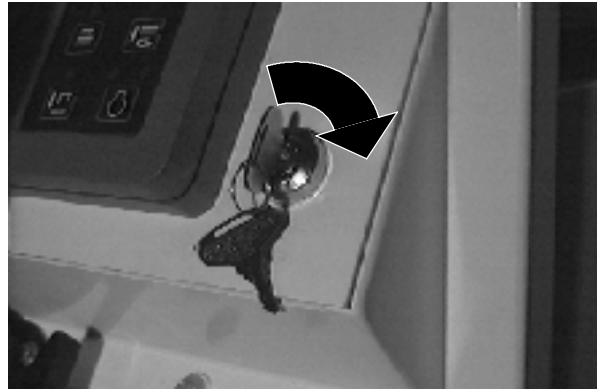

2. Move the throttle lever to the fast position.

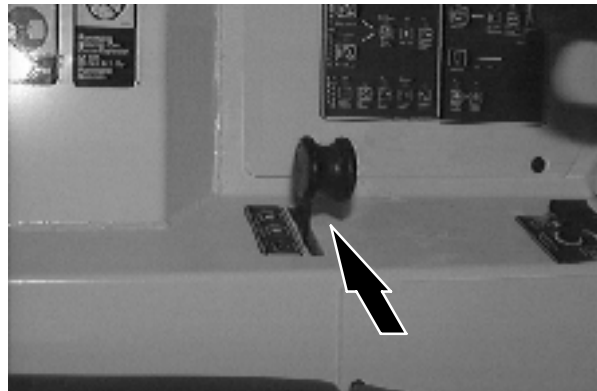

3. Press the main sweep brush speed 1 switch for normal sweeping, or main sweep brush speed 2 switch for sweeping light litter.

The side brush will automatically lower and start if the side brush switch is on, the sweeping vacuum will start, the hopper door will open.

4. Sweep as needed.

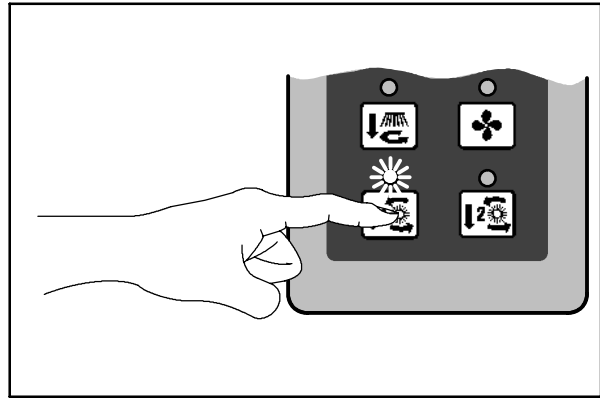

09561

---

**STOP SWEEPING**

---

1. Press the main sweep brush speed 1 switch, or main sweep brush speed 2 switch to stop the sweeping operations.

The main brush will stop and raise, the side brush will stop and raise, the sweeping vacuum will stop, the hopper door will close, the filter shaker will operate for a short time, and the engine speed will remain at (Fast).

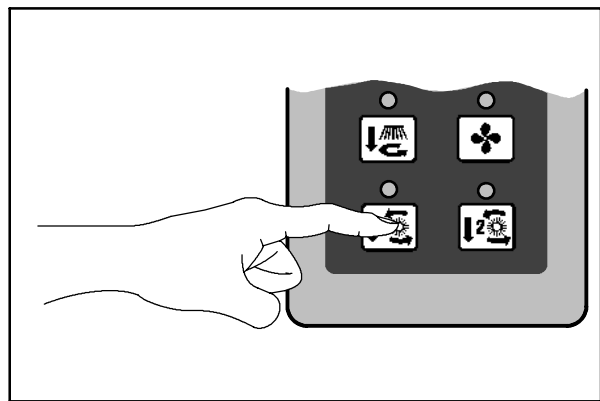

09564

## EMPTYING THE HOPPER

1. Slowly drive the machine to the debris site or debris container.
2. Make sure the indicator light above the hopper door switch is on to show the hopper door is closed. If not, press the hopper door switch.

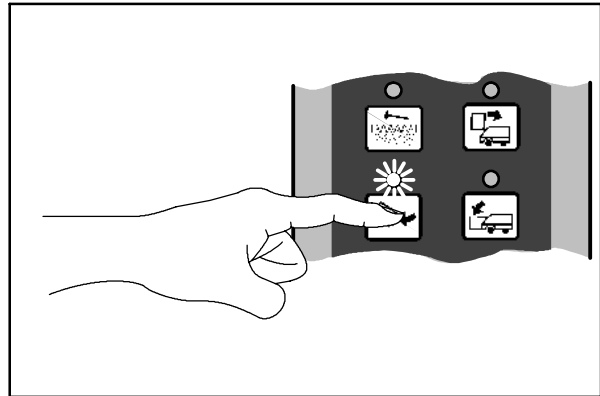

09568

3. Press the filter shaker switch to shake the hopper dust filter.

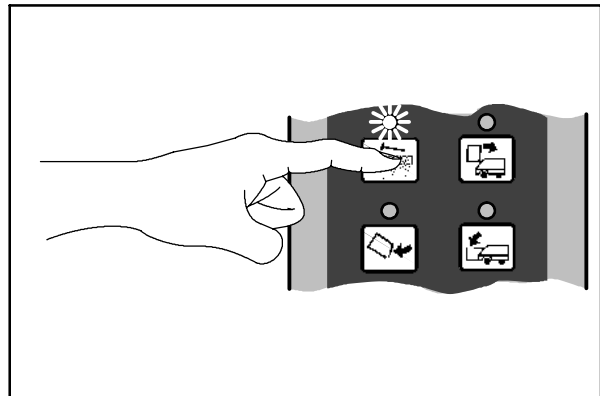

09567

4. Press and hold the hopper raise switch to raise the hopper to the desired height.

**FOR SAFETY: When using machine, make sure adequate clearance is available before raising hopper.**

*NOTE: Be aware that the minimum ceiling height needed to high dump the hopper is 2490 mm (98 in).*

**FOR SAFETY: When using machine, move machine with care when hopper is raised.**

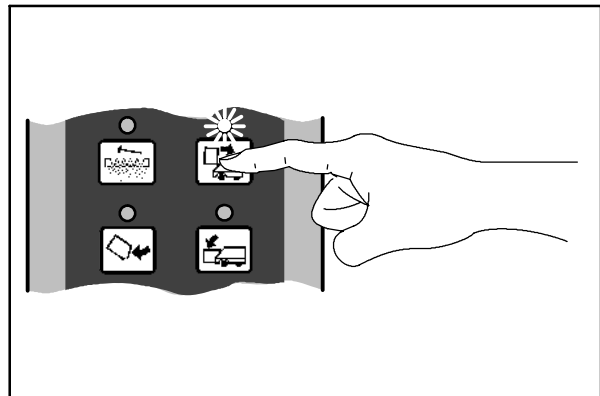

09569

5. Drive the machine up to the debris container.
6. Push the hopper door switch to open the hopper door. The indicator light above the switch goes out.
7. Slowly back the machine away from the debris site or debris container.

**FOR SAFETY: When using machine, use care when reversing machine.**

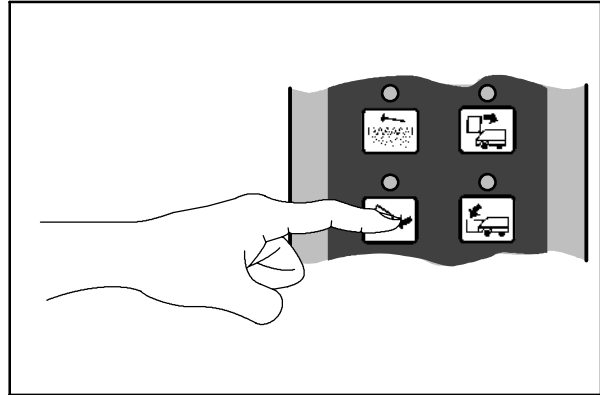

09570

8. Push the hopper door switch to close the hopper door. The indicator light above the switch comes on.

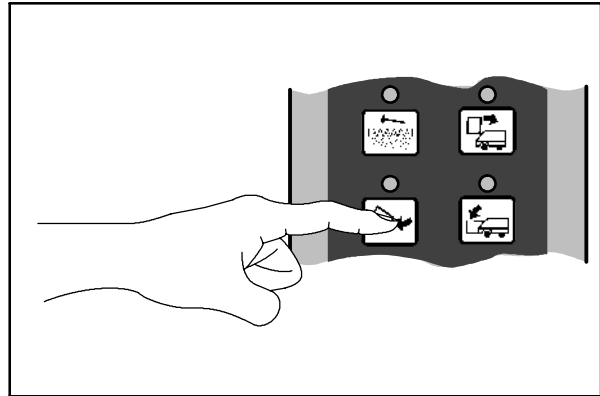

09570

9. Press and hold the hopper down switch to lower the hopper.

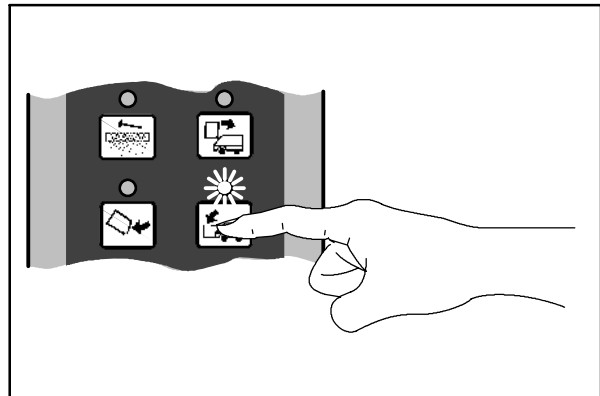

09571

## FILLING THE TANKS

1. Start the engine.
2. Drive the machine to the filling site.

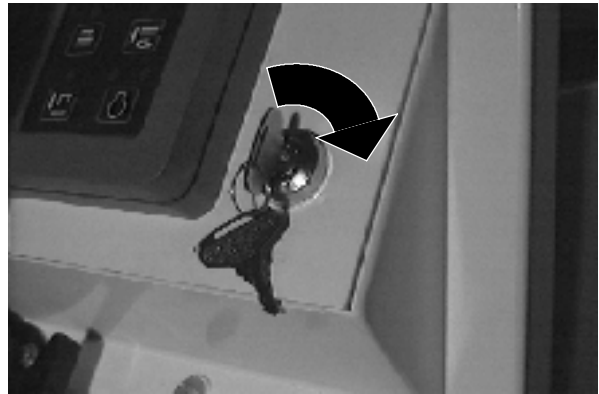

3. Shut the engine off.
4. Set the parking brake.

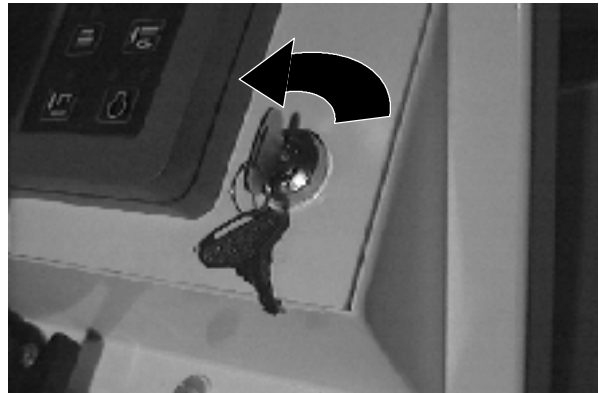

5. **CONVENTIONAL SCRUBBING:** Open the tank cover. Start filling the solution tank with water. Pour the required amount of detergent into the solution tank. Fill the solution tank to 75 mm (3 in) below the tank opening.

*NOTE: Floor conditions, water condition, amount of soilage, type of soilage, and brush action all play an important role in determining the type and concentration of detergent used. For specific recommendations, contact your Tennant representative.*



**WARNING: Flammable materials can cause an explosion or fire. Do not use flammable materials in tank(s).**

**FOR SAFETY: Follow mixing and handling instructions on chemical containers.**

6. FaST SCRUBBING: Open the solution tank covers and fill the solution tanks to 75 mm (3 in) below the tank openings with cool clear water only. Do not add cleaning detergents.

**NOTE: When cleaning using FaST, USE CLEAR COOL WATER ONLY. DO NOT add cleaning agents in solution tank. Conventional cleaning agents/restorers may cause failure to the FaST solution system.**

ES mode: Lift up the operator seat. Remove the detergent tank lid and pour the required amount of detergent into the tank. Put the lid back on the detergent tank and lower the operator seat.



**WARNING: Flammable materials can cause an explosion or fire. Do not use flammable materials in tank(s).**

NOTE: Floor conditions, water condition, amount of soilage, type of soilage, brush action all play an important role in determining the type and concentration of detergent used. For specific recommendations, contact your TENNANT representative.

ES mode with auto-fill: Connect the hose from the water source to the auto-fill connection on the machine. Turn the ignition key to the on position and turn on the water source. The auto-fill will automatically fill the tanks to the proper level for ES operation and automatically shut-off.

ES mode without auto-fill: The ES tanks can also be filled manually by filling the solution tank to 75 mm (3 in) below tank opening, and filling recovery tank half full.

NOTE: If you **do not** want to use the ES system, do not put any water in the recovery tank. Turn off the ES switch.

7. Close the tank cover.

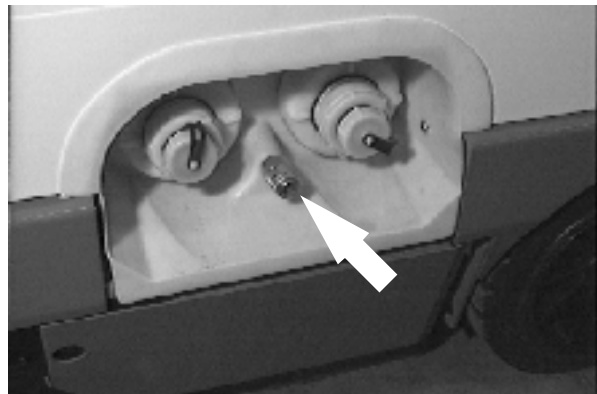

# OPERATION

---

## SCRUBBING

---

1. Start the engine.

**FOR SAFETY:** When starting machine, keep foot on brake and directional pedal in neutral.

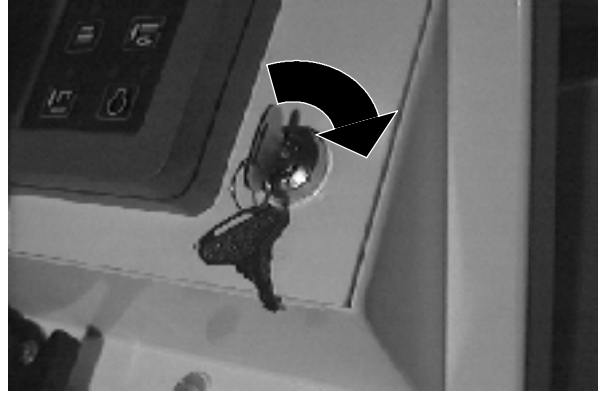

2. Move the throttle lever to the **fast** position.

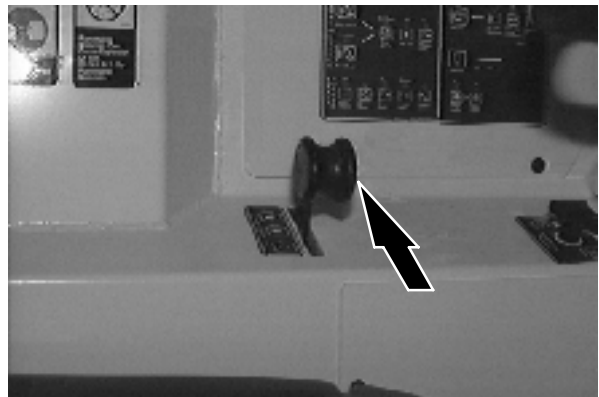

3. Drive the machine to the area to be cleaned.



4. **FaST SCRUBBING:** Press the FaST switch to the FaST system on position and press the FaST solution flow switch to the desired solution flow. See the SOLUTION FLOW SWITCH (FaST) section of the manual.

*NOTE: Leave the FaST switch in the CONVENTIONAL SCRUBBING position if not using the FaST system.*

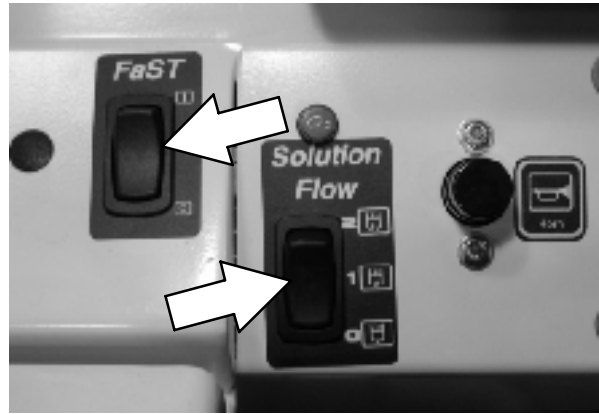

5. **CONVENTIONAL SCRUBBING:** Adjust the solution flow to the floor as needed. See the SOLUTION SWITCH (WITHOUT FaST) section of the manual.

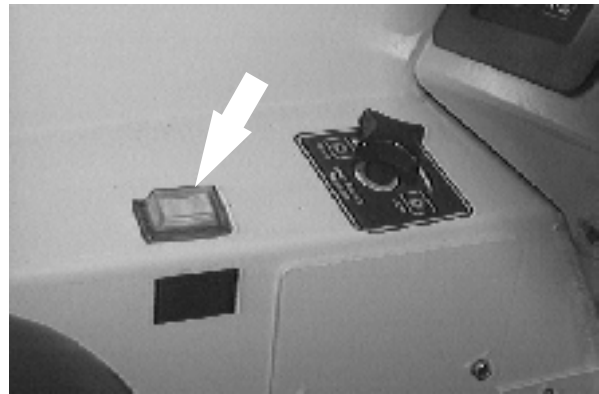

## OPERATION

6. Press the scrub switch to start the scrubbing operation.

As long as the machine is not in reverse, the scrub head will lower and the scrub brushes will start. The rear squeegee will automatically lower and the scrubbing vacuum will start. The solution flow will start, if the solution flow switch is on. Also the optional ES system and detergent pump will start, if the switches are on.

**WARNING: Flammable materials or reactive metals can cause explosion or fire. Do not pick up.**

*NOTE: If you **do not** want to use the ES system, press the ES switch so the indicator above the switch is off. Press and hold the detergent switch until both indicator lights are off. Turn off the detergent only if detergent has been added to the solution tank.*

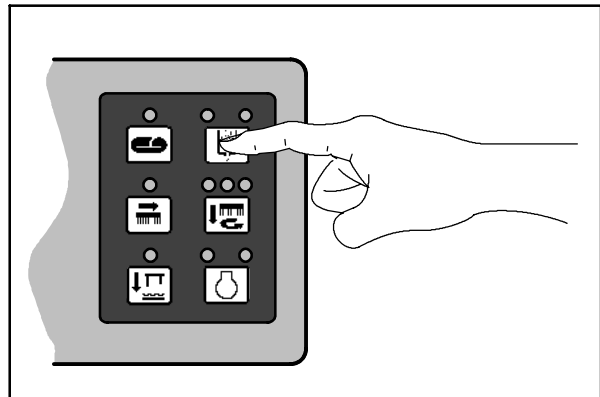
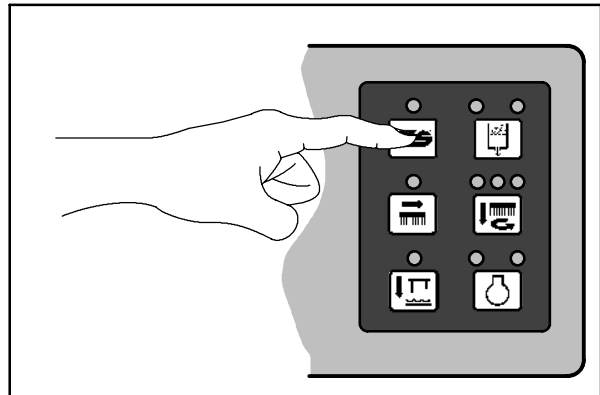
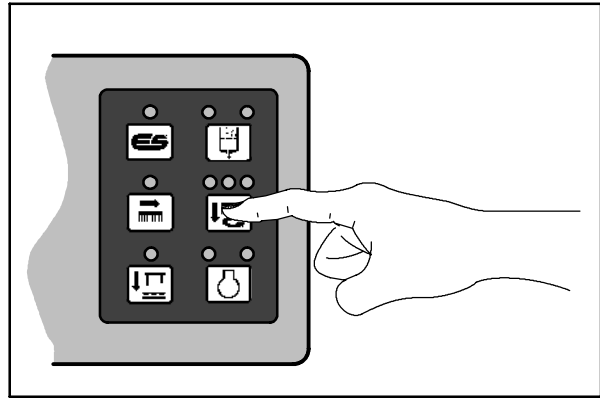

7. Adjust brush pressure for cleaning application.

The brush pressure has three positions. Under normal conditions, the brush pressure should be set in the minimum setting. Under heavy grime conditions, the brush pressure should be set in the maximum setting.

8. Drive the machine forward and scrub as required.

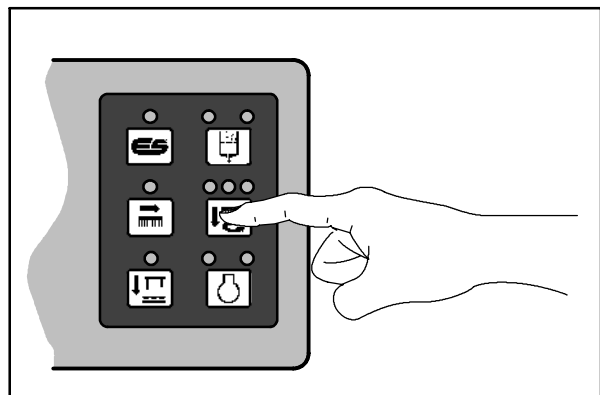

---

## DOUBLE SCRUBBING

---

Double scrubbing is a method for removing heavy floor accumulations. This is done by making two passes over the area to be cleaned with the machine.

Double scrubbing can be performed using the FaST SCRUBBING SYSTEM or CONVENTIONAL SCRUBBING methods.

First, make a pass over the area scrubbing with the squeegee up. This dispenses solution over the area allowing the solution to soak on the floor. Use the maximum solution and detergent flow settings. Use a higher brush pressure setting. Let the solution remain on the floor for 5 to 15 minutes. Then make a second pass scrubbing with the squeegee down.

**FOR SAFETY: When using machine, go slow on inclines and slippery surfaces.**

---

## STOP SCRUBBING

---

1. Press the scrub switch to stop the scrubbing operations.

The scrub brushes will stop and the scrub head will raise. The ES detergent pump will stop, and the solution flow will stop, the FaST system will stop. After a short delay, the rear squeegee will automatically raise and the scrubbing vacuum fan will stop. The engine speed will remain at (Fast).

Drive the machine forward until the vacuum fan shuts off.

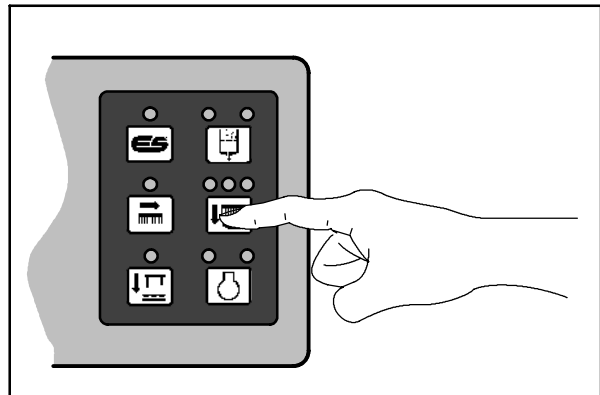

11110

### DRAINING AND CLEANING THE TANKS

---

When you are finished scrubbing or you hear the vacuum fan shut off and the machine starts trailing water, the recovery tank should be drained and cleaned. The solution tank then can be filled again for additional scrubbing.

If you used the machine in ES mode, the solution tank should also be drained and cleaned when you are finished scrubbing.

1. Stop scrubbing.
2. Drive the machine next to an appropriate disposal site.
3. Shut the engine off.

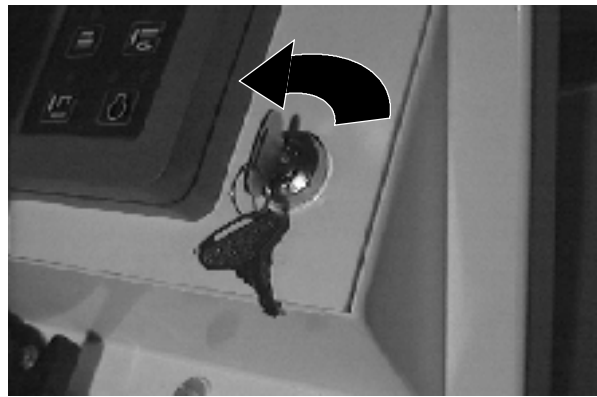

4. Set the parking brake.

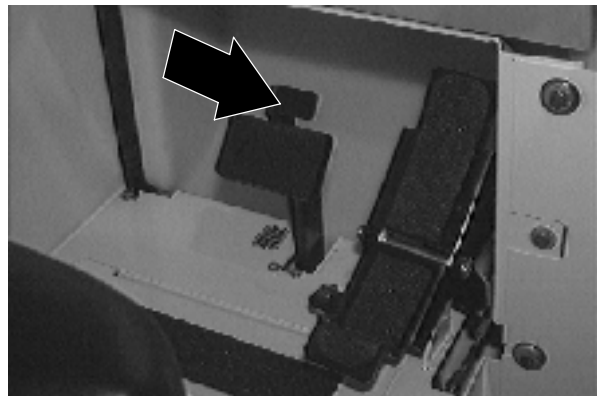

5. Unscrew the drain hose cap from the access cap of the recovery tank drain.
6. Pull out and place the drain hoses next to the floor drain. Remove the drain end cap from the hose. Stand back, the solution rushes out of the drain hoses.

*NOTE: To prevent the solution from rushing out of the recovery tank drain hose, leave the engine on and lower the rear squeegee to start up the vacuum fan, before removing the drain hose end cap. Once the drain hose is placed next to the floor drain, raise the squeegee and shut off the engine. Be sure to set the machine parking brake.*



7. Open the tank cover.
8. Spray the inside of the recovery tank with clean water.



9. Remove the large drain cap and flush out the bottom on the recovery tank.

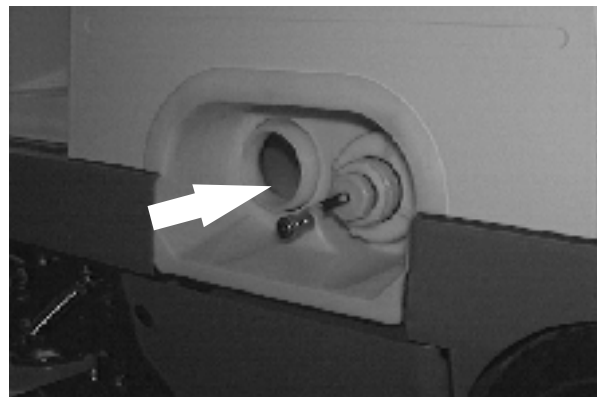

10. ES mode: Clean the ES filter. If the filter can't be rinsed off through the recovery tank fill opening, the filter can be removed from the recovery tank by disconnecting the ES pump wire and solution hose, and unscrewing the ES pump cap from the recovery tank.

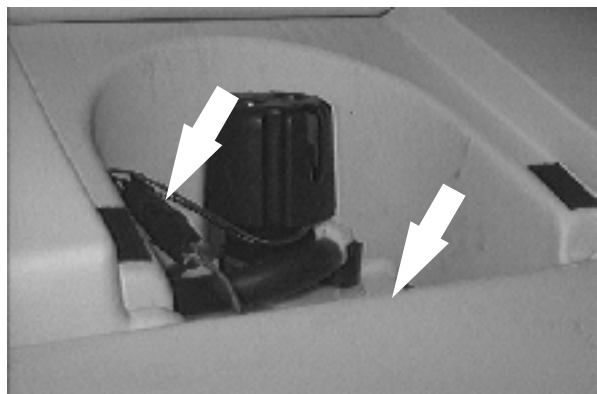

## OPERATION

11. ES mode: Drain the solution tank. Flush out the solution tank with clean water. Rinse the solution outlet filters at the bottom of the tank through the drain access.
12. Lower the tank cover.
13. Replace the drain hoses and drain caps.

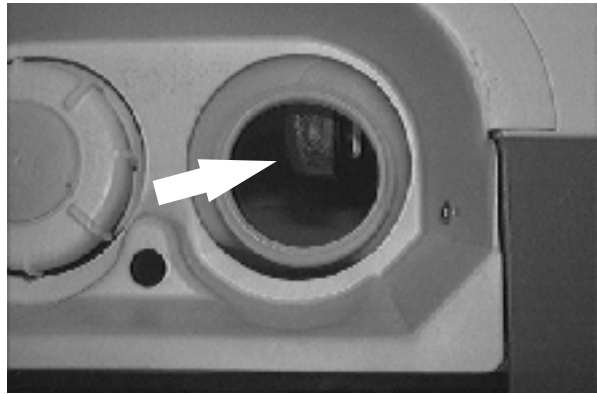

---

## STOP THE MACHINE

---

1. Stop sweeping and scrubbing.
2. Take your foot off the directional pedal. Step on the brake pedal.

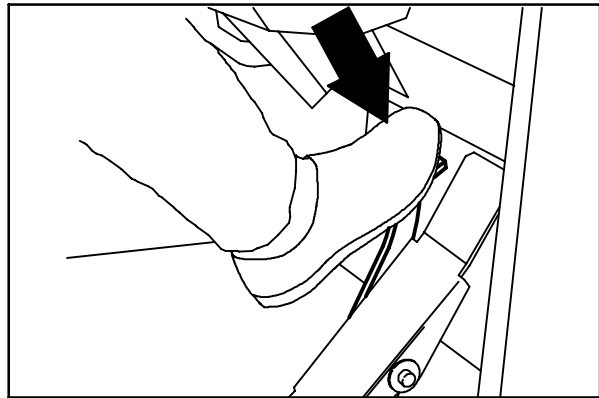

07754

3. Move the throttle lever to the **idle** position.



4. Set the machine parking brake.

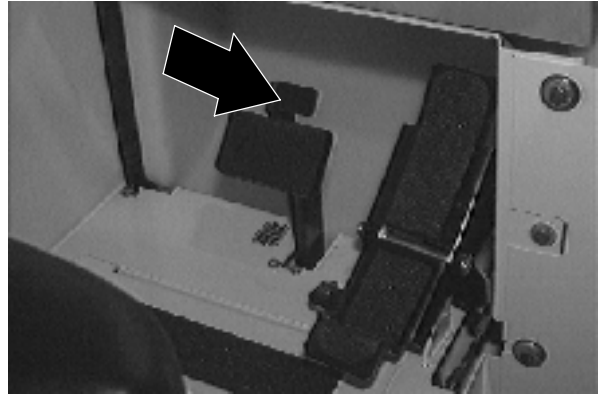

5. Turn the ignition switch key counter-clockwise to stop the engine. Remove the switch key.

**FOR SAFETY: Before leaving or servicing machine; stop on level surface, set parking brake, turn off machine and remove key.**



## POST-OPERATION CHECKLIST

---

- Check the brushes adjustment. See *TO CHECK AND ADJUST MAIN BRUSH PATTERN* and *SIDE BRUSH* in *MAINTENANCE*.
- Check for wire, string, or twine wrapped around the sweeping and scrub brushes.
- Check the brush skirts for damage, wear, and adjustments.
- Check the squeegees for wear or damage.
- Drain and clean the recovery tank.
- ES mode: Drain and clean the solution tank and clean the solution outlet filter. Clean the ES filter.
- Check the vacuum hoses for debris or obstructions.
- Check for fuel odor that indicates a fuel leak.
- Check under the machine for leak spots (fuel, oil, coolant, scrubbing solution).
- Empty hopper and clean dust filter.
- Check the service records to determine maintenance requirements.
- FaST Scrubbing: If FaST PAK is empty after scrubbing, install a new FaST PAK or connect supply hose to the storage plug.



---

**ENGAGING HOPPER SUPPORT BAR**

---

1. Set the machine parking brake.

**FOR SAFETY: When starting machine, keep foot on brake and directional pedal in neutral.**

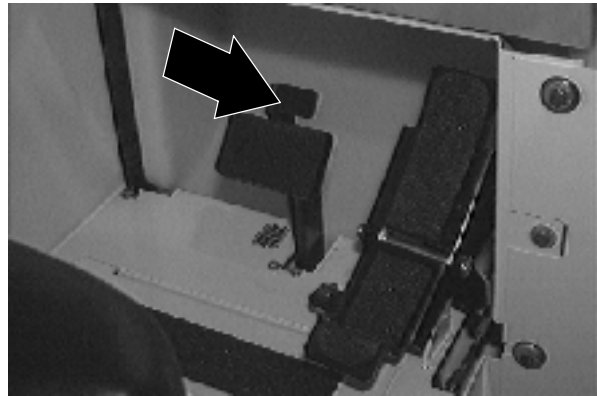

2. Start the engine.

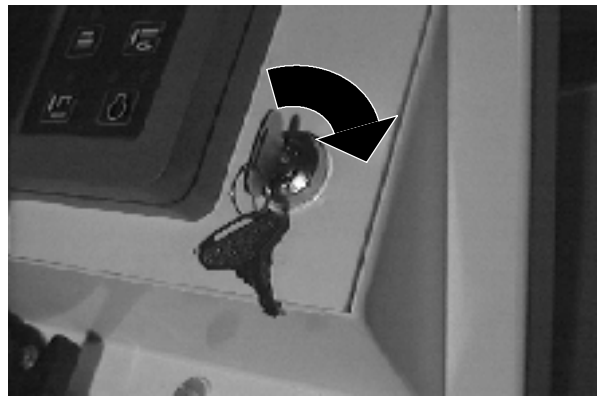

3. Raise the hopper all the way up.

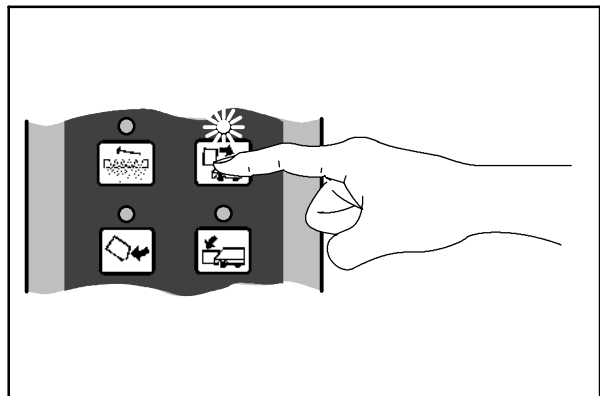

09569

4. Lift and position the hopper support bar under the hopper lift arm.

 **WARNING: Raised hopper may fall. Engage hopper support bar.**

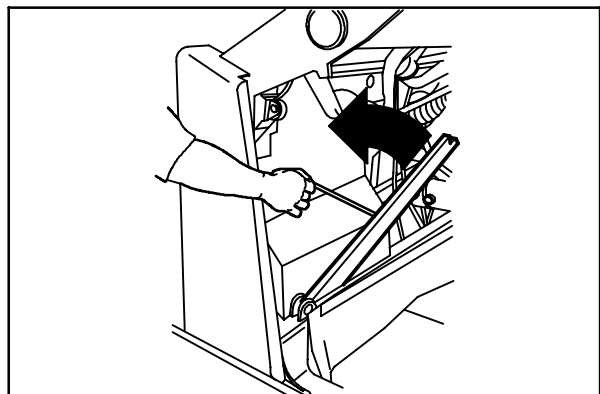

08003

## OPERATION

5. Slowly lower the hopper so the lift arm rests on the support bar.



**WARNING:** Lift arm pinch point. Stay clear of hopper lift arms.

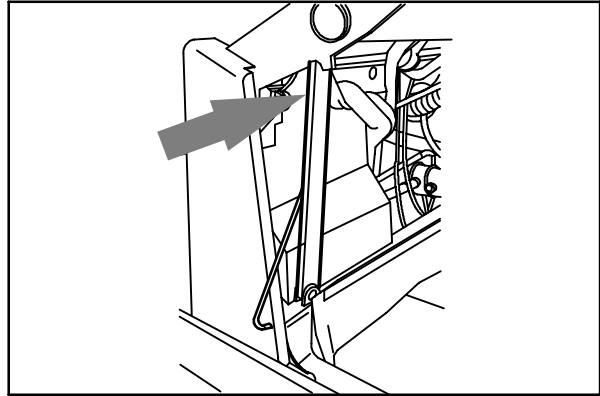

07803

6. Shut the engine off.



---

## DISENGAGING HOPPER SUPPORT BAR

---

1. Start the engine.

**FOR SAFETY:** When starting machine, keep foot on brake and directional pedal in neutral.

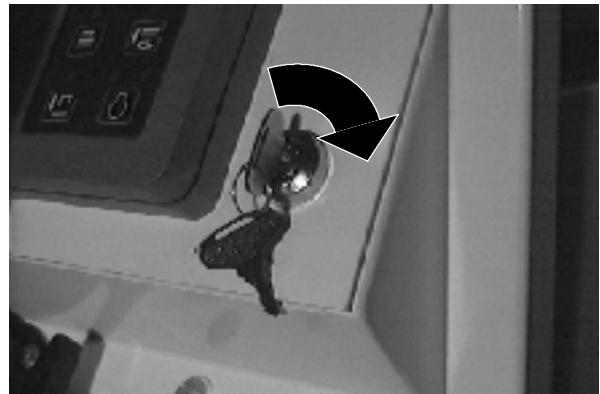

2. Raise the hopper slightly to release the hopper support bar.

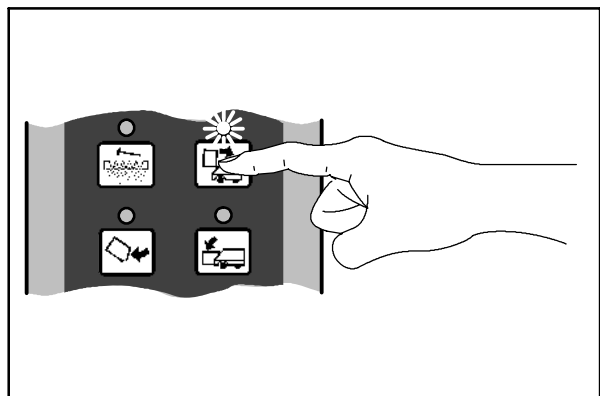

09569

3. Put the support bar in its storage position.

**!** **WARNING: Lift arm pinch point. Stay clear of hopper lift arms.**

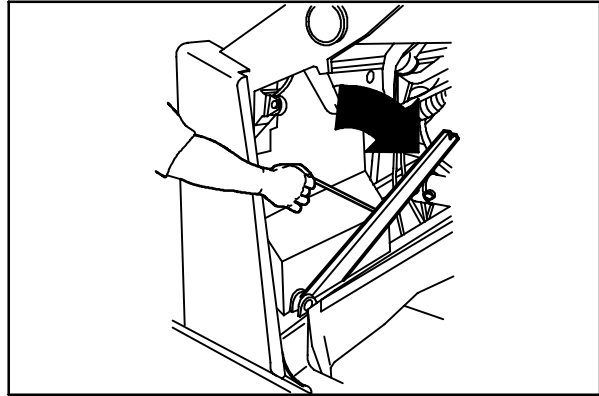

08004

4. Lower the hopper.

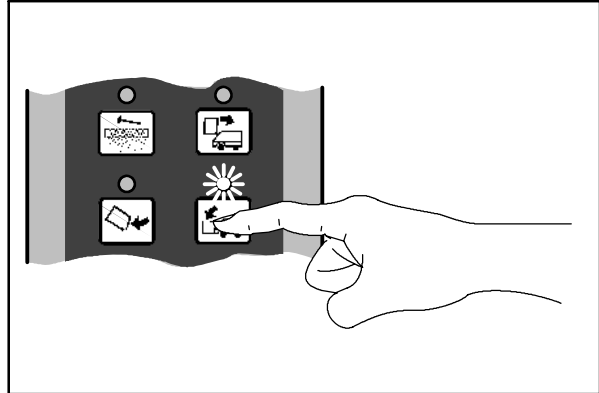

09571

5. Shut the engine off.

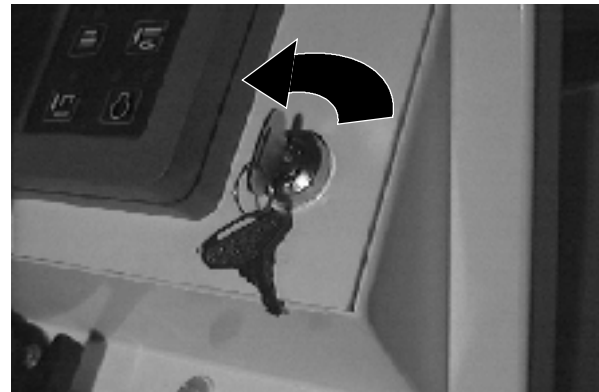

---

**OPERATION ON INCLINES**

---

Drive the machine slowly on inclines. Use the brake pedal to control machine speed on descending inclines.

The maximum rated incline for sweeping and scrubbing with the machine is 6°. The maximum rated incline during transport of the machine is 8°.

**FOR SAFETY: When using machine, go slow on inclines and slippery surfaces.**

## OPTIONS

### VACUUM WAND (WET)

The vacuum wand uses the machine's vacuum system. The vacuum hose allows pick-up of spills that are out of reach of the machine.

1. Stop the machine within reach of the area to be vacuumed.
2. Lower the squeegee and shut the engine off.

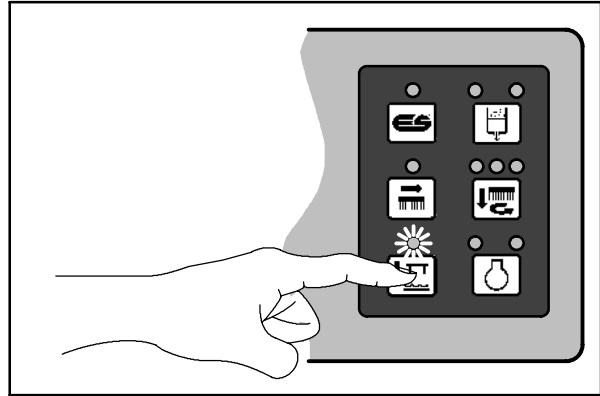

11114

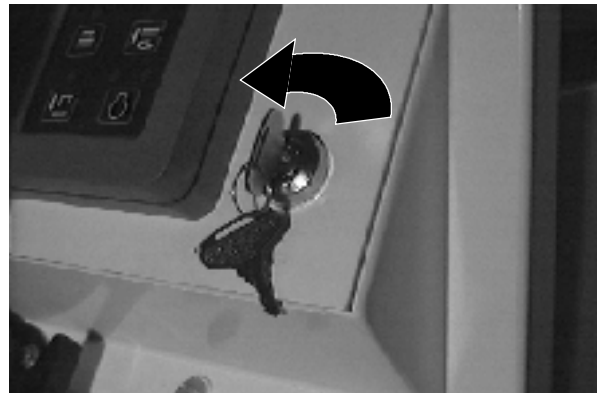

3. Set the machine parking brake.

**FOR SAFETY: Before leaving or servicing machine; stop on level surface, set parking brake, turn off machine and remove key.**

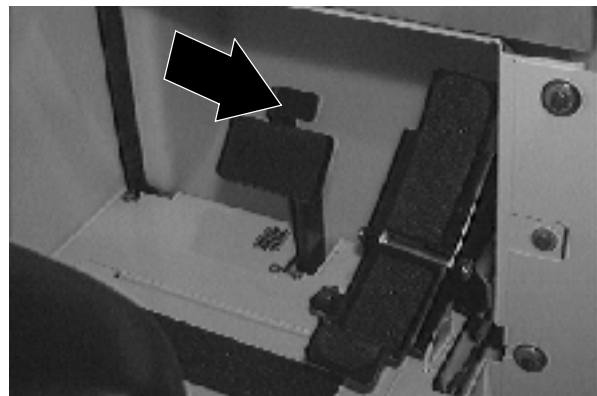

4. Remove the squeegee suction hose from the rear squeegee and connect the vacuum hose.

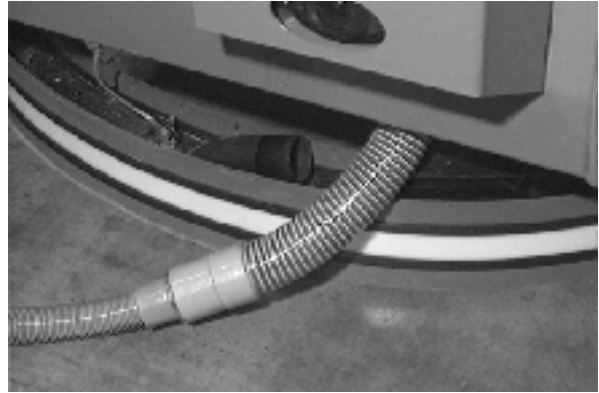

5. Put together the wand and the wand hose.
6. Start the engine.

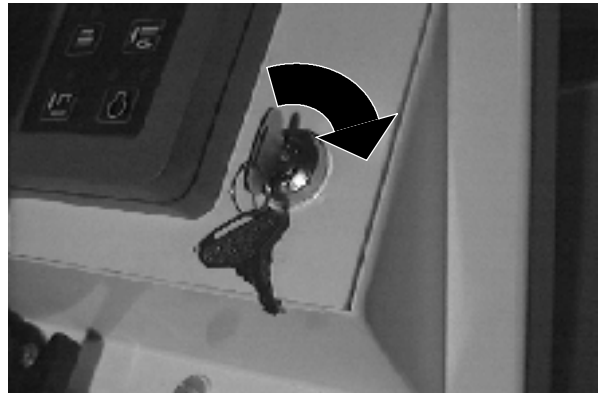

7. Move the throttle lever to the **fast** position.

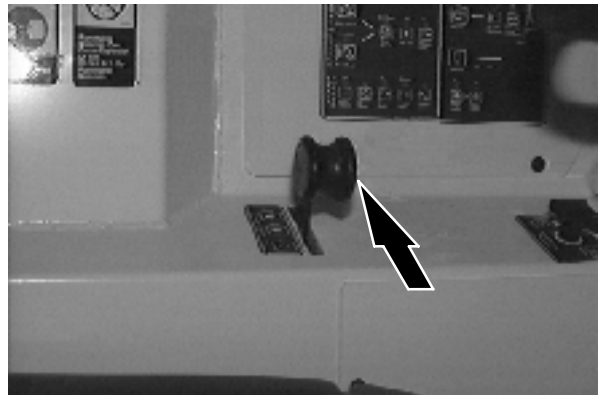

8. Lower the squeegee to turn the vacuum system on.

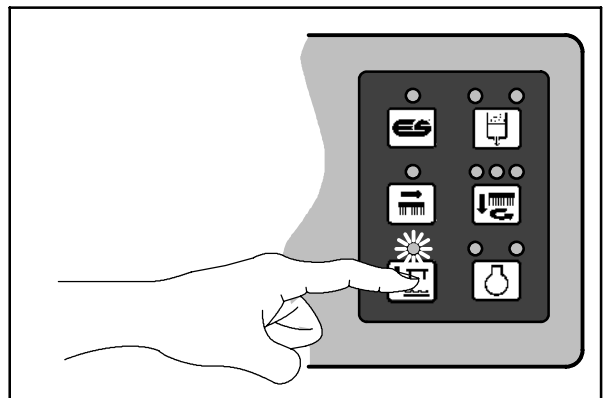

11114

## OPERATION

9. Vacuum the floor.



10. Shut the engine off.



11. Remove the vacuum hose from the squeegee suction hose and connect the squeegee suction hose to the rear squeegee.

12. Put the vacuum wand and hose in the mounting clips.

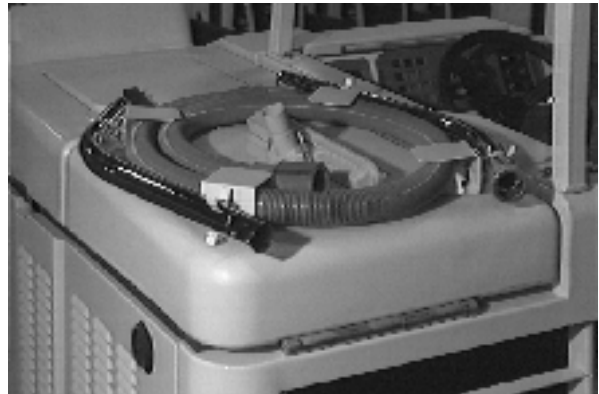

**MACHINE TROUBLESHOOTING**

Problem	Cause	Remedy
Excessive dusting	Brush skirts and dust seals worn, damaged, out of adjustment	Replace or adjust brush skirts or dust seals
	Hopper dust filter clogged	Shake and/or clean or replace dust filter
	Vacuum hose damaged	Replace vacuum hose
	Vacuum fan failure	Contact TENNANT service personnel
	Thermo Sentry tripped	Reset Thermo Sentry
Poor sweeping performance	Brush bristles worn	Replace brushes
	Main and side brushes not adjusted properly	Adjust main and side brushes
	Debris caught in main brush drive mechanism	Free drive mechanism of debris
	Main brush drive failure	Contact TENNANT service personnel
	Side brush drive failure	Contact TENNANT service personnel
	Hopper full	Empty hopper
	Hopper lip skirts worn or damaged	Replace lip skirts
	Wrong sweeping brush	Contact TENNANT representative for recommendations

Problem	Cause	Remedy
FaST System does not operate	FaST switch is set for Conventional scrubbing	Set the FaST switch for FaST system scrubbing
	FaST circuit breaker tripped	Determine cause and reset the 10A circuit breaker button
	Clogged FaST PAK supply hose and/or connector	Soak connector and hose in warm water and clean
	FaST PAK carton is empty or not connected	Replace FaST PAK carton and/or connect supply hose
	FaST system is not primed	To prime, operate the FaST solution system for 5 to 10 minutes.
	Clogged flow control orifice/screen	Remove and clean orifice/screen
	Faulty pump or air compressor	Contact TENNANT representative
	Clogged filter screen	Drain solution tank, remove and clean filter screen
	Faulty detergent timer module	Contact Tennant representative
	FaST solution flow switch is off	Turn FaST solution flow switch on

## OPERATION

Problem	Cause	Remedy	
Trailing water - poor or no water pickup.	Worn rear squeegee blades.	Rotate or replace squeegee blades.	
	Rear squeegee out of adjustment.	Adjust rear squeegee.	
	Side squeegees raised.	Lower side squeegees.	
	Worn side squeegee blades.	Replace side squeegee blades.	
	Side squeegees out of adjustment.	Adjust side squeegees.	
	Tank cover not seated.	Reseat tank cover.	
	Tank cover seals worn.	Replace seals.	
	Too much solution flow to floor.	Reduce solution flow to floor.	
	Vacuum hose clogged.	Flush vacuum hoses.	
	Recovery tank full.		Drain recovery tank.
			Check ES pump and filter
	Float stuck shutting off vacuum.	Clean float.	
	Debris caught on rear squeegee.	Remove debris.	
	Foam filling recovery tank.	Empty recovery tank; use less or change detergent.	
	Vacuum hose to rear squeegee disconnected or damaged.	Reconnect or replace vacuum hose.	
Vacuum fan to recovery tank hose damaged.	Replace hose.		
Little or no solution flow to the floor.	Solution tank empty.	Fill solution tank.	
	Solution flow switch turned off.	Turn solution flow switch on.	
	Solution supply lines plugged.	Flush solution supply lines.	
	ES switch off.	Turn ES switch on.	
Poor scrubbing performance.	Debris caught on scrub brushes.	Remove debris.	
	Improper detergent or brushes used.	Check with TENNANT representative for advice.	
	Worn scrub brushes.	Replace scrub brushes.	
ES system does not fill solution tank.	Clogged solution pump or lines.	Flush ES system.	
	ES float stuck.	Clean floats of debris.	
	Clogged ES pump filter.	Clean filter.	
	Water levels too low in tanks.	Add water.	





**MAINTENANCE**

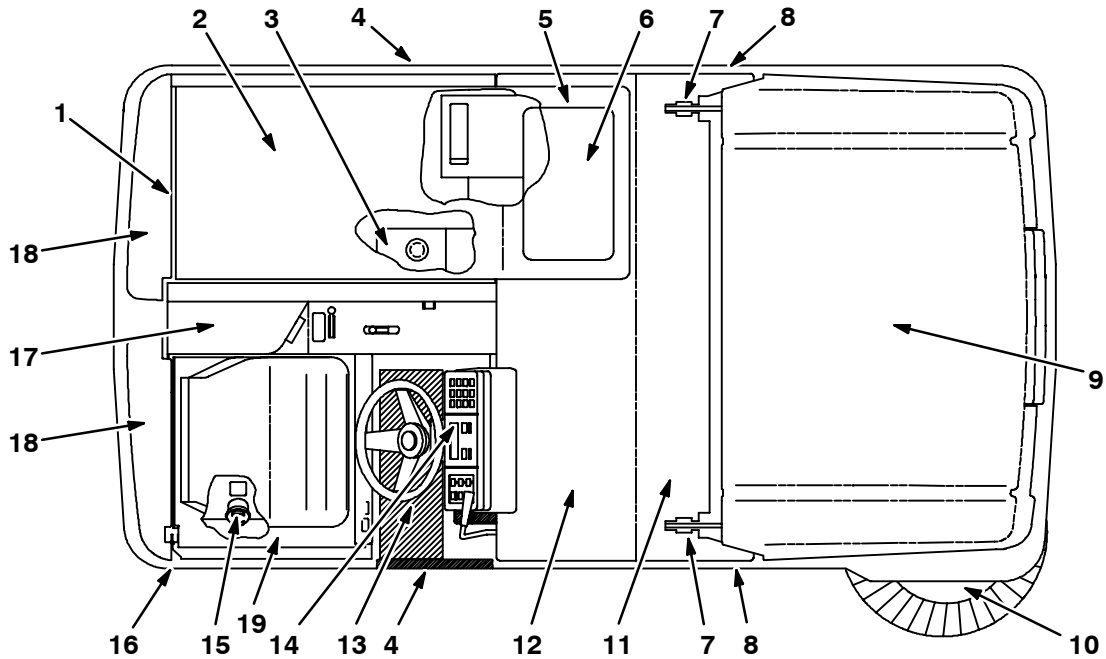

09076

**MAINTENANCE CHART**

*NOTE: Check procedures indicated (■) after the first 50-hours of operation.*

Interval	Key	Description	Procedure	Lubricant/ Fluid	No. of Service Points
Daily	2	Engine air filter	Check indicator	-	1
			Empty dust cap	-	1
	2	Engine crankcase	Check oil level	EO	1
			Check coolant level in reservoir	WG	1
	11	Brush compartment skirts	Check for damage, wear and adjustment	-	5
	9	Hopper lip skirts	Check for damage, wear and adjustment	-	3
	11	Main sweep brush	Check for damage, wear, and adjustment	-	1
			Check brush pattern	-	1
	10	Side brush	Check for damage, wear, and adjustment	-	1
			Check brush pattern	-	1
	9	Hopper dust filter	Shake	-	2
	16	Rear Squeegee	Check for damage and wear	-	1
			Check deflection	-	1
	4	Side Squeegees	Check for damage and wear	-	2
	4	Scrub brushes	Check for damage and wear	-	1
	5	Recovery tank	Clean	-	1
	12	Recovery tank, ES mode	Clean ES filter	-	1
6	Solution tank, ES mode	Clean	-	1	
19	FaST PAK supply hose and connector	Clean and connect hose to storing plug when not in use	-	1	

Interval	Key	Description	Procedure	Lubricant/ Fluid	No. of Service Points
50 Hours	11	Main sweep brush	Rotate end-for-end	-	1
	2	Fuel pipes and clamps	Check for tightness and wear	-	1
	2	Engine crankcase	Change oil and filter	EO	1
	18	Rear squeegee casters	Lubricate	SPL	2
	19	FaST fiilter screen	Clean	-	1
100 Hours	1	Radiator	Clean core exterior	-	1
			Check coolant level	WG	1
	2	Engine belt	Check tension	-	1
	9	Hopper dust filter	Check for damage, clean or re- place	-	1
	3	Hydraulic fluid reservoir	Check fluid level	HYDO	1
	8	Tires	Check for damage	-	3
	11	Main sweep brush and hopper seals	Check for damage or wear	-	8
200 Hours	16	Rear squeegee	Check leveling	-	1
	1	Radiator hoses and clamps	Check for tightness and wear	-	2
			14	Parking brake	Check adjustment
	14	Brake pedal	Check and adjust travel	-	1
	17	Rear wheel support bear- ings	Lubricate	SPL	2
	10	Side brush guard	Rotate 90°	-	1
	7	Lift arm pivots	Lubricate	SPL	4
	9	Hopper door pivots	Lubricate	SPL	2
19	FaST Air filter	Clean	-	1	
400 Hours	8	Front wheel bearings	Check, lubricate, and adjust	SPL	2
	2	Fuel filter	Replace cartridge	-	1
	15	Fuel tank	Remove sediment	-	1
	1	Cooling system	Flush	WG	1
800 Hours	3	Hydraulic reservoir	Replace filler cap	-	1
			Replace suction strainer	-	1
			Change hydraulic fluid	HYDO	1
	3	Hydraulic fluid filter	Change filter element	-	1
	-	Hydraulic hoses	Check for wear and damage	-	All
	17	Propelling motor	■Torque shaft nut	-	1
	17	Rear wheel	■Torque wheel nuts	-	1
	13	Battery	■Clean and tighten battery cable connections	-	1
Check electrolyte			DW	1	

**LUBRICANT/FLUID**

EO . . . . Engine oil, SAE-CC/CD rated

HYDO . . . Tennant Company or approved hydraulic fluid

WG . . . . Water and permanent-type ethylene glycol anti-freeze, -34° C (-30° F)

SPL . . . . Special lubricant, Lubriplate EMB grease (Tennant part number 01433-1)

DW . . . . Distilled water

*NOTE: More frequent intervals may be required in extremely dusty conditions.*

## LUBRICATION

### ENGINE

Check the engine oil level daily. Change the engine oil and oil filter every 50 hours of machine operation. Use 10W30 SAE-CC/CD/CE rated engine oil.

Fill the engine with oil to the level indicated on the oil dipstick. Low oil level is indicated by the mark closest to the end of the dipstick. Full level is indicated by the mark closest to the top of the dipstick. The engine oil capacity is 6.15 L (6.5 qt) without the oil filter.

The engine oil filter is mounted on the right side of the machine frame above the scrub brushes.

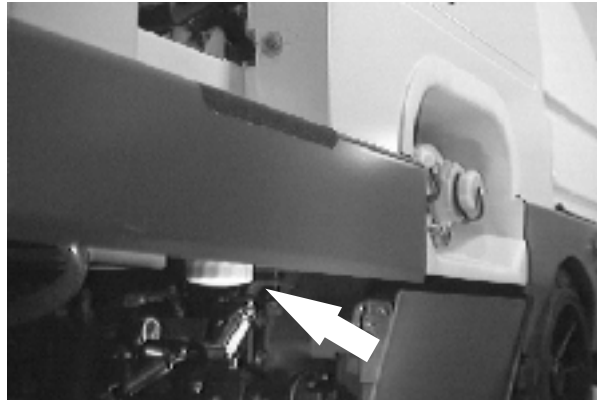
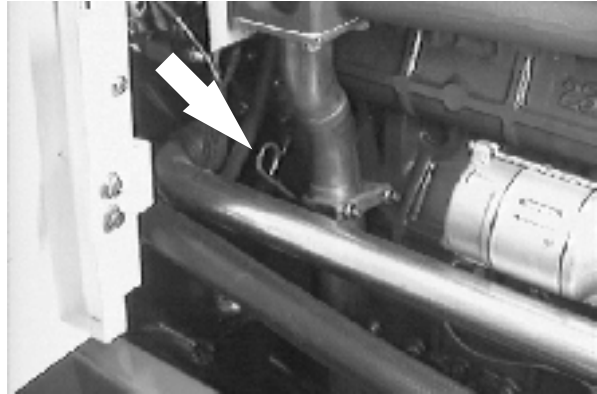

### REAR WHEEL SUPPORT

The rear wheel support pivots the rear wheel. The support has two grease fittings for the bearings. The rear wheel support bearings must be lubricated every 200 hours of operation. Use Lubriplate EMB grease (Tennant part number 01433-1).

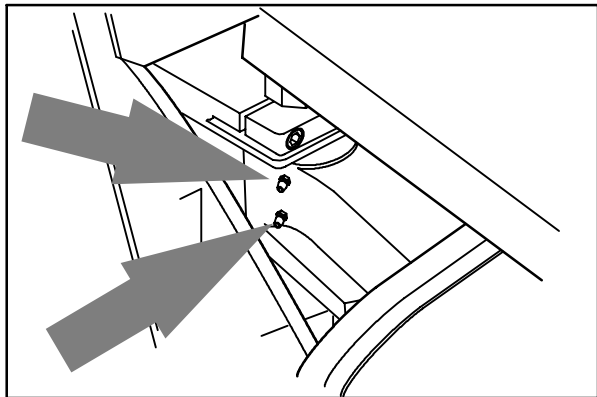

08005

**FRONT WHEEL BEARINGS**

Inspect the front wheel bearings for seal damage, and repack and adjust every 400 hours of operation. Use Lubriplate EMB grease (Tennant part number 01433-1).

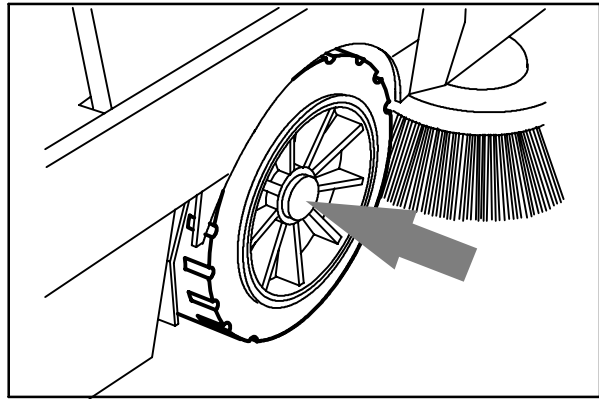

08006

**HOPPER LIFT ARM PIVOTS**

The hopper lift arms have four grease fittings, two on each lift arm. One fitting is at the top pivot of the lift arm, and the other is at the middle pivot.

The lift arms should be lubricated with Lubriplate EMB grease (Tennant part number 01433-1) every 200 hours of operation.

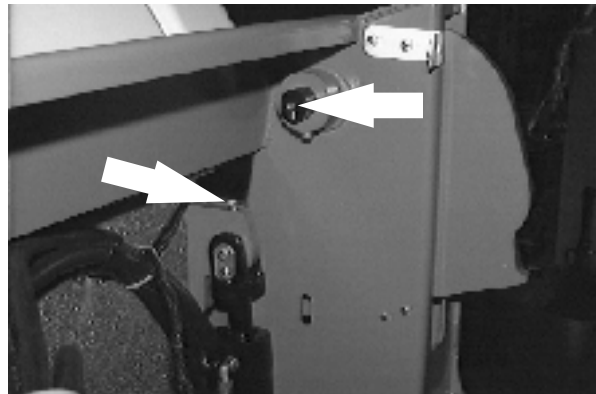

**HOPPER DOOR PIVOTS**

The hopper door pivot has two grease fittings, one on each side of the hopper. The hopper door should be lubricated with Lubriplate EMB grease (Tennant part number 01433-1) every 200 hours of operation.

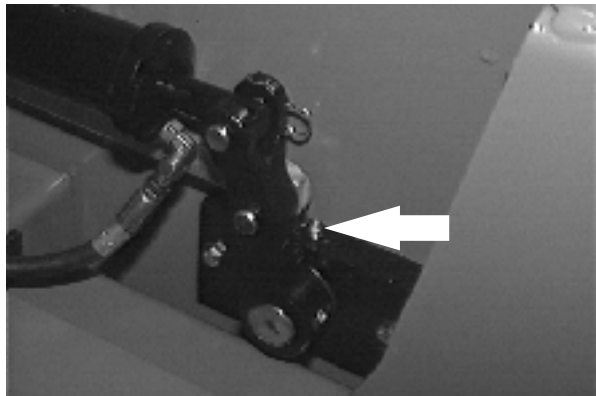

**REAR SQUEEGEE CASTERS (for machines below serial number 012215)**

Each of the rear casters has a grease fitting. The casters must be lubricated every 50 hours of operation. Use Lubriplate EMB grease (Tennant part number 01433-1).

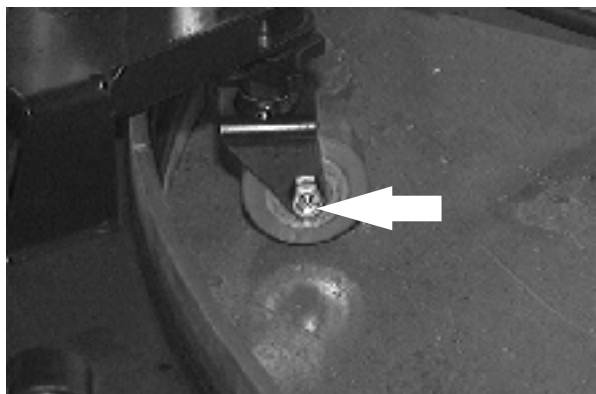

## HYDRAULICS

### HYDRAULIC FLUID RESERVOIR

The reservoir is located in the engine compartment next to the radiator.

Mounted on top of the reservoir is a filler cap with a built-in breather and fluid level dipstick. Replace the cap every 800 hours of operation.

Check the hydraulic fluid level at operating temperature every 100 hours of operation. Make sure the hopper is down when checking hydraulic fluid level. The end of the dipstick is marked with FULL and ADD levels to indicate the level of hydraulic fluid in the reservoir.

Lubricate the filler cap gasket with a film of hydraulic fluid before putting the cap back on the reservoir.

**ATTENTION! Do not overfill the hydraulic fluid reservoir or operate the machine with a low level of hydraulic fluid in the reservoir. Damage to the machine hydraulic system may result.**

Drain and refill the hydraulic fluid reservoir with new hydraulic fluid every 800 hours of operation.

The hydraulic fluid filter is located at the bottom of the engine compartment. Replace the filter element every 800 hours of operation.

The reservoir has a built-in strainer outlet that filters hydraulic fluid before it enters the system. Replace the strainer every 800 hours of operation.

### HYDRAULIC FLUID

The quality and condition of the hydraulic fluid play a very important role in how well the machine operates. Tennant's hydraulic fluid is specially selected to meet the needs of Tennant machines.

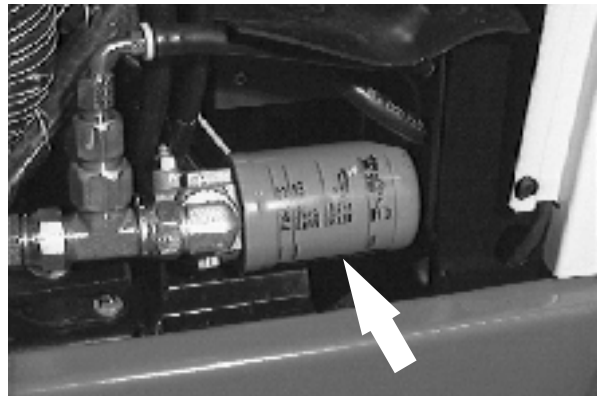
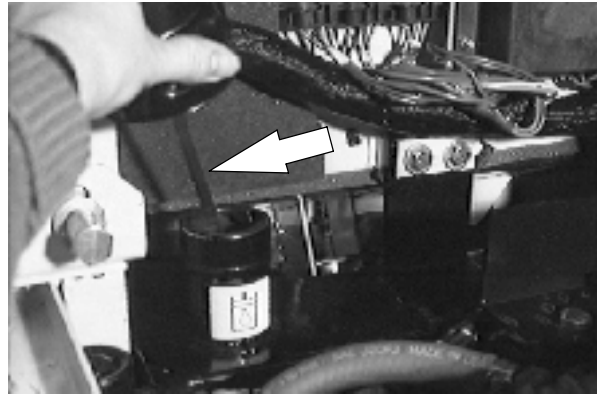

Tennant's hydraulic fluids provide a longer life for the hydraulic components. There are two fluids available for different temperature ranges:

Tennant part no.	Ambient Temperature
65869	above 7° C (45° F)
65870	below 7° C (45° F)

The higher temperature fluid has a higher viscosity and should not be used at the lower temperatures. Damage to the hydraulic pumps may occur because of improper lubrication.

The lower temperature fluid is a thinner fluid for colder temperatures.

If a locally-available hydraulic fluid is used, make sure the specifications match Tennant hydraulic fluid specifications. Using substitute fluids can cause premature failure of hydraulic components.

**ATTENTION! Hydraulic components depend on system hydraulic fluid for internal lubrication. Malfunctions, accelerated wear, and damage will result if dirt or other contaminants enter the hydraulic system.**

**HYDRAULIC HOSES**

Check the hydraulic hoses every 800 hours of operation for wear or damage.

Fluid escaping at high pressure from a very small hole can be almost invisible, and can cause serious injuries.

See a doctor at once if injury results from escaping hydraulic fluid. Serious infection or reaction can develop if proper medical treatment is not given immediately.

**FOR SAFETY: When servicing machine, use cardboard to locate leaking hydraulic fluid under pressure.**

If you discover a fluid leak, contact your mechanic or supervisor.

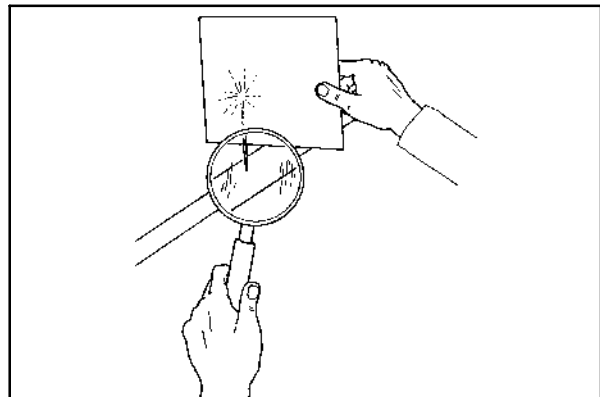

00002

**PROPELLING MOTOR**

Torque the shaft nut to 508 Nm (375 ft lb) lubricated, 644 Nm (475 ft lb) dry after the first 50-hours of operation, and every 800 hours thereafter.

## ENGINE

### COOLING SYSTEM

Check the coolant level in the reservoir daily.

Check the radiator coolant level every 100 hours of operation. Use clean water mixed with a permanent-type, ethylene glycol antifreeze to a  $-34^{\circ}\text{C}$  ( $-30^{\circ}\text{F}$ ) rating.

**FOR SAFETY: When servicing machine, avoid contact with hot engine coolant.**

Check the radiator hoses and clamps every 200 hours of operation. Tighten the clamps if they are loose. Replace the hoses and clamps if the hoses are cracked, harden, or swollen.

Check the radiator core exterior and hydraulic cooler fins for debris every 100 hours of operation. Open the radiator grille for cleaning access. Blow or rinse all dust, which may have collected on the radiator, in through the grille and radiator fins, opposite the direction of normal air flow. Be careful not to bend the cooling fins when cleaning. Clean thoroughly to prevent the fins becoming encrusted with dust. Clean the radiator and cooler only after the radiator has cooled to avoid cracking.

**FOR SAFETY: When servicing machine, wear eye and ear protection when using pressurized air or water.**

Flush the radiator and the cooling system every 800 hours of operation, using a dependable cleaning compound.

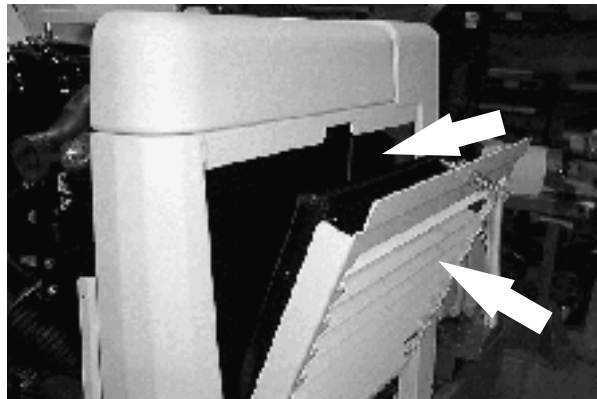
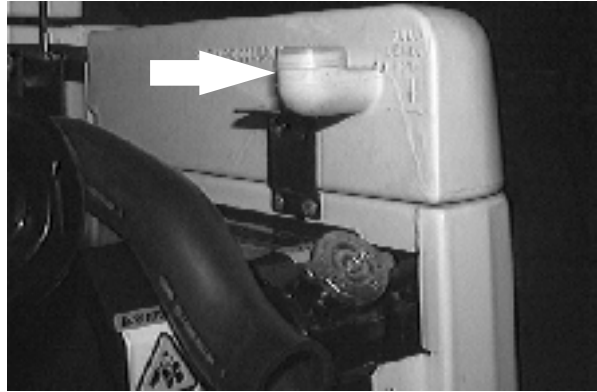



**AIR FILTER INDICATOR**

The air filter indicator shows when to replace the air filter element. Check the indicator daily. The indicator's red line will move as the air filter element fills with dirt. Do not replace the air filter element until the red line reaches 5 kPa (20 in H<sub>2</sub>O) and the "SERVICE WHEN RED" window is filled with red. The indicator's red line may return to a lower reading on the scale when the engine shuts off. The red line will return to a correct reading after the engine runs for a while.

Reset the air filter indicator by pushing the reset button on the end of the indicator after replacing the air filter element.

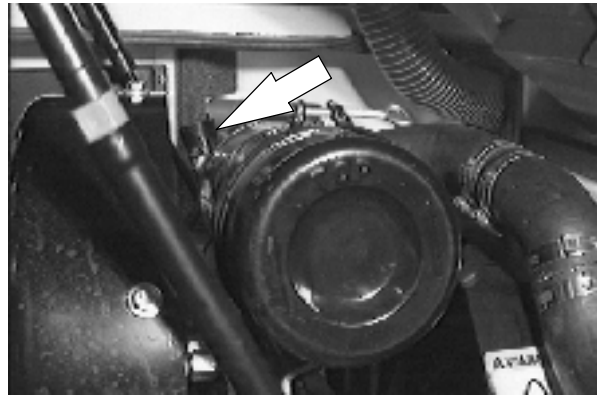

**AIR FILTER**

The engine air filter housing has a dust cap and a dry cartridge-type air filter element. Empty the dust cap daily. The air filter must be replaced whenever the filter element is damaged or when the air filter indicator shows a restriction. The air filters cannot be cleaned.

Machines with the heavy duty air filter option have a safety element. It is inside the standard element. Replace this element after the regular element becomes damaged or changed three times.

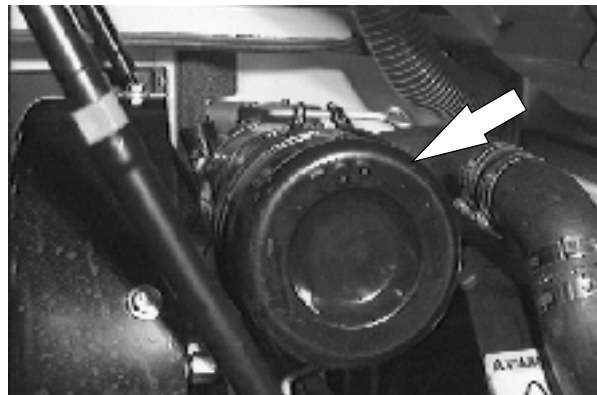

Install the dust cap on the air filter housing with the arrows pointing up.

Replace the air filter element only when the air filter indicator shows restriction in the air intake system. Do not remove the air filter element from the housing unless it is restricting air flow.

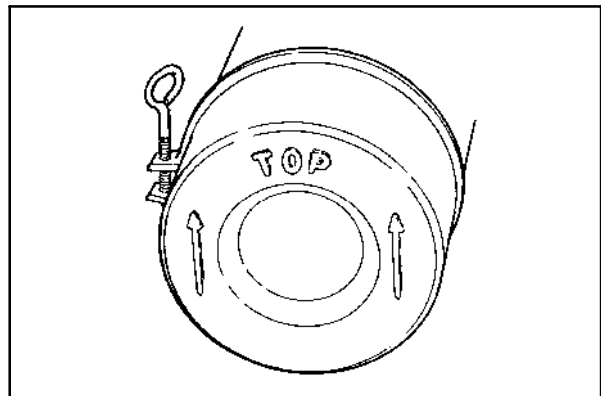

02492

## FUEL FILTER

The fuel filter cartridge filters impurities from the fuel. The filter is located by the fuel tank.

Replace the fuel filter element every 400 hours of operation.

## FUEL LINES

Check the fuel lines every 50 hours of operation. If the clamp band is loose, apply oil to the screw of the band, and securely tighten the band.

Made of rubber, the fuel lines become worn out whether the engine has been used much or not. Replace the fuel lines and clamp bands every two years.

If the fuel lines and clamp bands are found worn or damaged before two years' time, replace or repair them at once. Bleed the fuel system after replacement of any of the fuel lines, see *PRIMING THE FUEL SYSTEM*. When the fuel lines are not installed, plug both ends with clean cloth or paper to prevent dirt from entering the lines. Dirt in the lines can cause fuel injection pump malfunction.

## PRIMING THE FUEL SYSTEM

Priming the fuel system removes pockets of air in the fuel lines and fuel components. Air in the fuel system will prevent smooth engine operation.

Prime the fuel system after running out of fuel, changing fuel filter elements or repairing a fuel system component.

1. Stop the engine and set the machine parking brake.

**FOR SAFETY: Before leaving or servicing machine; stop on level surface, set parking brake, and turn off machine.**

2. Fill the fuel tank.
3. Open the side and top engine access doors.

**FOR SAFETY: When servicing machine, allow engine to cool. Keep flames and sparks away from fuel system service area. Keep area well ventilated.**

4. Open the air vent on top of the fuel injection pump.

5. Start the engine, operate it for one minute, then stop it; or operate the starter motor in ten-second intervals until a steady stream of fuel flows from the vent.
6. Close the air vent.
7. Close the access doors.

---

**BATTERY**

---

The battery for the machine is a low maintenance battery. Do not add water to the battery, or remove the battery vent plugs.

The battery is located at the bottom of the operator compartment.

After the first 50 hours of operation, and every 800 hours after that, clean and tighten the battery connections.

**FOR SAFETY: When servicing machine, avoid contact with battery acid.**

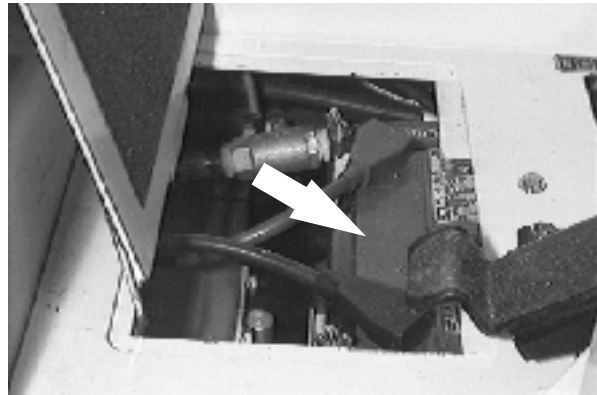

## BELTS AND CHAINS

### ENGINE BELT

The engine belt is driven by the engine crankshaft pulley and drives the engine water pump and alternator pulleys. Proper belt tension is obtained when the belt deflects 7 to 9 mm (0.28 to 0.35 in) from a force of 10 kg (22 lb) applied at the mid-point of the longest span.

Check and adjust the belt tension every 100 hours of operation.



**WARNING: Moving belt and fan. Keep away.**

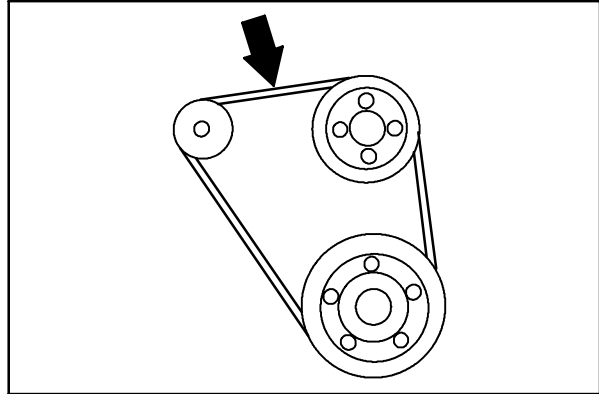

08935

### STATIC DRAG CHAIN

A static drag chain prevents the buildup of static electricity in the machine. The chain is attached to the machine by a rear main brush skirt retaining bolt.

Make sure the chain is touching the floor at all times.

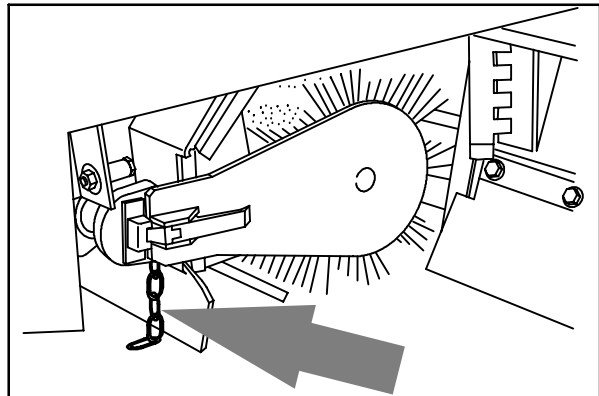

08009

**DEBRIS HOPPER**

**HOPPER DUST FILTER**

The dust filter filters the air pulled up from the hopper. The dust filter is equipped with a shaker to remove the accumulated dust particles. The dust filter shaker is operated by the filter shaker switch.

Shake the dust filter before emptying the hopper and at the end of every work shift. Check and clean or replace the dust filter every 100 hours of operation.

To clean the dust filter, use one of the following methods:

- **SHAKING** - Press the filter shaker switch.
- **TAPPING** - Tap the filter gently on a flat surface with the dirty side down. Do not damage the edges of the filter element or the filter will not seat properly in the filter frame.
- **AIR** - Always wear eye protection when using compressed air. Blow air through the dust filter opposite the direction of the arrows. Never use more than 690 kPa (100 psi) of air pressure and never closer than 50 mm (2 in) away from the filter.

**FOR SAFETY: When servicing machine, wear eye and ear protection when using pressurized air or water.**

- **WATER** - The dust filter can be rinsed with water, but the filter will degrade with each rinsing. Replaced the filter after rinsing five times. Rinse with a low pressure garden hose through the dust filter opposite the direction of the arrows.

*NOTE: Be sure the dust filter is dry before reinstalling it in the machine.*

**REMOVING HOPPER DUST FILTER**

8. Stop the engine and set the machine parking brake.

**FOR SAFETY: Before leaving or servicing machine; stop on level surface, set parking brake, turn off machine and remove key.**

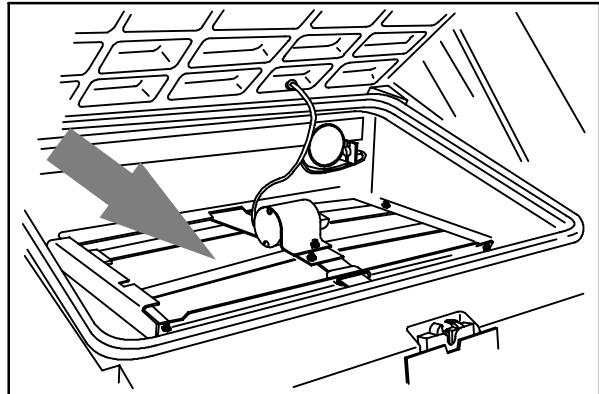

08010

## MAINTENANCE

9. Open the hopper cover.
10. Disconnect the shaker motor wire connectors.

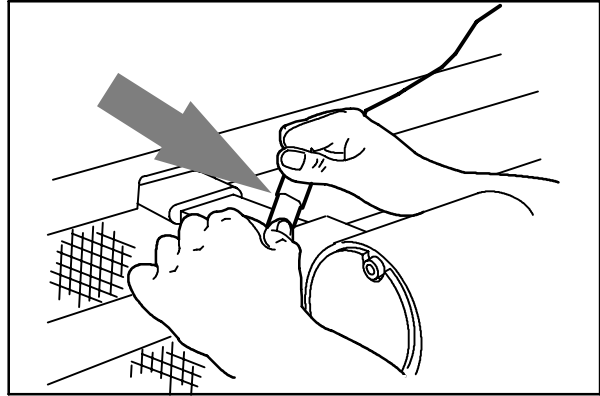

08011

11. Remove the four retaining nuts from the filter shaker frame.
12. Pull the filter shaker frame out of the hopper.

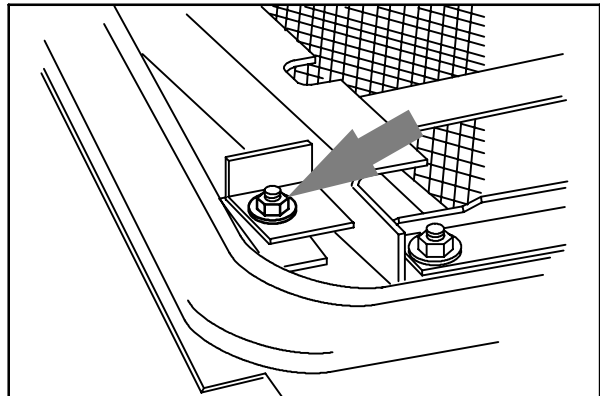

08014

13. Lift the dust filter element out of the hopper insert.
14. Clean or discard the dust filter as required.

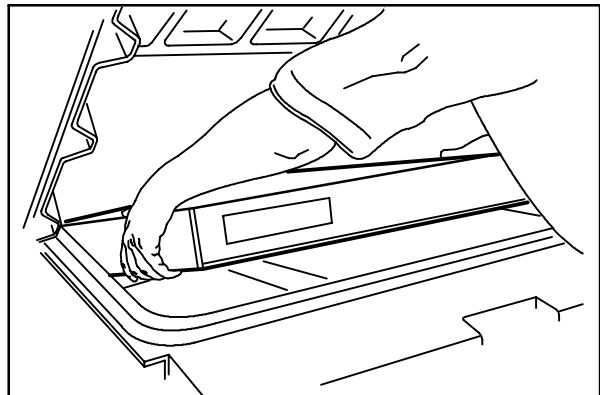

08012

15. Put the cleaned or new dust filter in the hopper insert with the arrows pointing up.
16. Put the shaker frame on top of the panel filter.
17. Install the four retaining nuts and tighten.
18. Connect the shaker motor wire connectors.

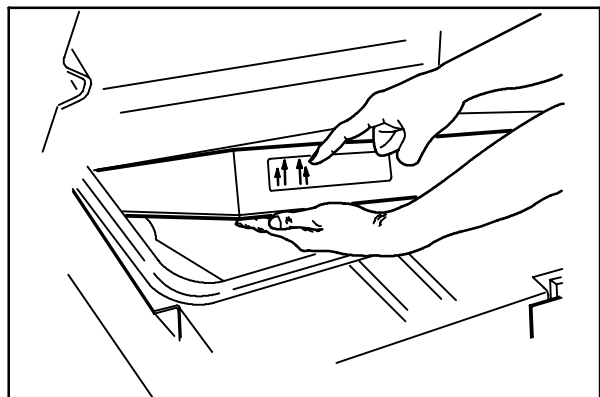

08013

**THERMO SENTRY**

The Thermo Sentry senses the temperature of the air pulled up from the hopper. If there is a fire in the hopper, the Thermo Sentry stops the vacuum fan and cuts off the air flow.

Reset the Thermo Sentry by pushing in its reset button.

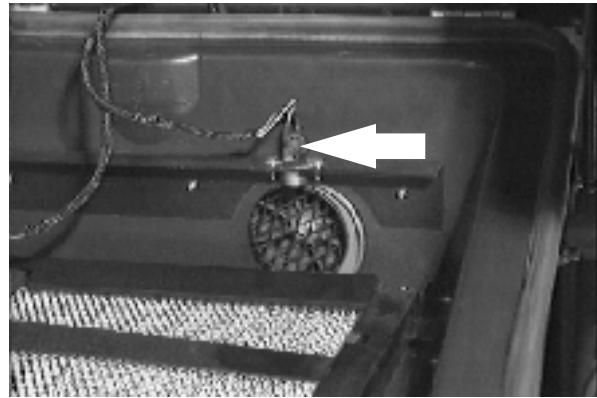

**SCRUB HEAD**

The scrub head encloses the scrub brushes and a solution dispensing system. The scrub head is located directly behind the sweeping brush compartment.

The scrub head is factory adjusted and the measurement should not be changed unless scrub head parts are damaged or are replaced.

**BRUSHES**

**MAIN SWEEP BRUSH**

The main sweep brush is cylindrical and spans the width of the machine, sweeping debris into the hopper.

Check the brush daily for wear or damage. Remove any string or wire tangled on the main brush, main brush drive hub, or main brush idler hub.

Check the main sweep brush pattern daily. The pattern should be 50 to 65 mm (2.0 to 2.5 in) wide with the main sweep brush in the lowered position. Adjust the main sweep brush pattern by turning the main brush pressure knob located next to the brush position lever.

Rotate the main brush end-for-end every 50 hours of operation for maximum brush life and best sweeping performance.

Sweeping performance often becomes less effective as the bristle length is worn. Replace the main brush when the remaining bristles measure between 40 mm (1 1/2 in) and 50 mm (2 in) in length.

## REPLACING MAIN SWEEP BRUSH

1. Stop the engine and set the machine parking brake.

**FOR SAFETY: Before leaving or servicing machine; stop on level surface, set parking brake, turn off machine and remove key.**

2. Raise the main sweep brush.
3. Open the right side brush access door.
4. Unlatch and remove the brush idler plate.

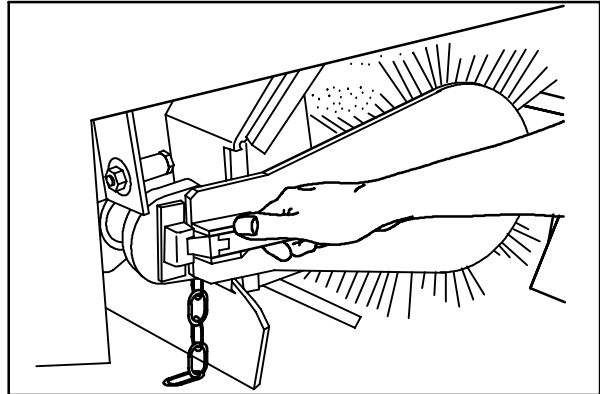

08016

5. Grasp the main sweep brush; pull it off the brush drive plug and out of the main brush compartment.
6. Put the new or rotated end-for-end main sweep brush on the floor next to the access door.
7. Slide the main sweep brush onto the drive plug. Rotate the brush until it engages the drive plug, and push it all the way onto the plug.

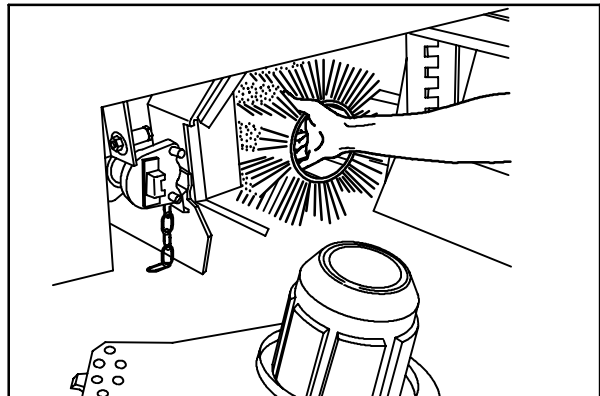

08017

8. Slide the brush idler plate plug onto the main sweep brush.
9. Latch the idler plate onto the machine frame.
10. Close the right side brush access door.

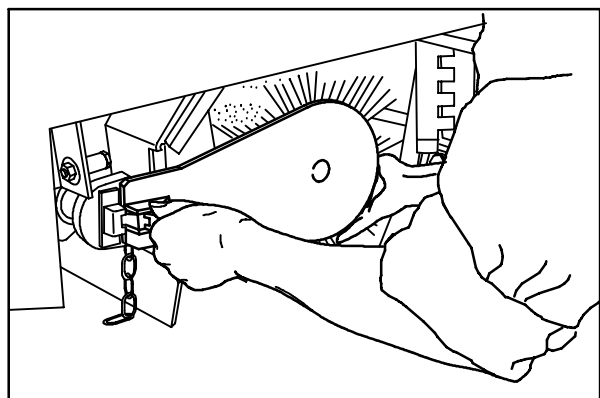

08018



**CHECKING AND ADJUSTING MAIN SWEEP BRUSH PATTERN**

1. Apply chalk, or some other material that will not blow away easily, to a smooth, level floor.
2. Raise the side brush and main sweep brush and position the main sweep brush over the chalked area.
3. Start the main sweep brush.
4. Lower the main sweep brush for 15 to 20 seconds while keeping a foot on the brakes to keep the machine from moving. This will lower the rotating main sweep brush.

*NOTE: If chalk or other material is not available, allow the sweep brush to spin on the floor for two minutes. A polish mark will remain on the floor.*

5. Raise the main sweep brush.
6. Stop the main sweep brush.
7. Drive the machine off the test area.
8. Observe the width of the brush pattern. The proper brush pattern width is 50 to 65 mm (2.0 to 2.5 in).

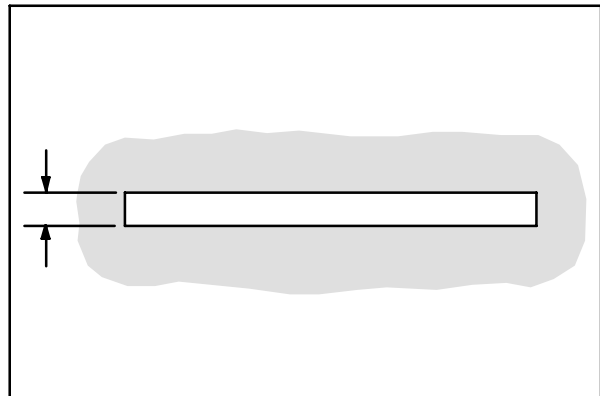

00582

9. To increase the width of the main sweep brush pattern, turn the main sweep brush down pressure knob counter-clockwise.

To decrease the width of the main sweep brush pattern, turn the main sweep brush down pressure knob clockwise.

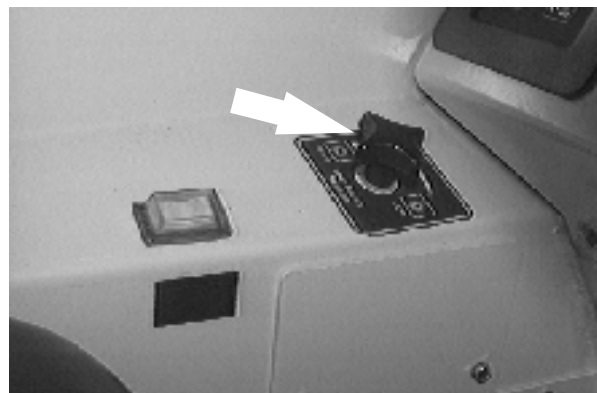

## MAINTENANCE

If the main sweep brush pattern is tapered, more than 15 mm (0.5 in) on one end than the other, adjust the taper with the taper adjustment bracket at the idler end of the brush.

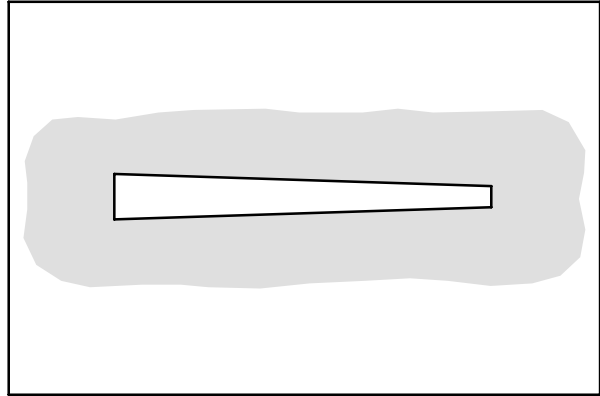

00601

- A. Loosen the bracket mounting bolts.

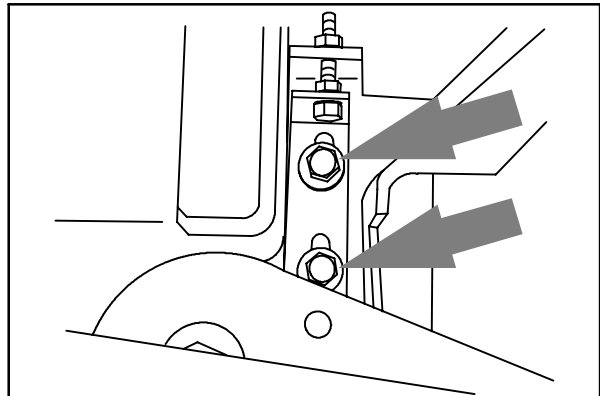

09183

- B. Turn the taper adjustment nut counter-clockwise to increase the pattern width at the brush idler end, and clockwise to decrease the pattern width at the brush idler end. Tighten the mounting bolts.
- C. Check the main sweep brush pattern and readjust as necessary. Then adjust the width of the main brush pattern.

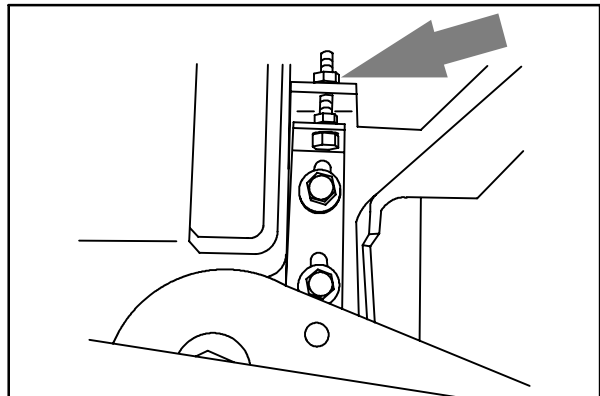

09184

**SIDE BRUSH**

The side brush sweeps debris along edges into the path of the main brush.

Check the brush daily for wear or damage. Remove any string or wire found tangled on the side brush or side brush drive hub.

Check the side brush pattern daily. The side brush bristles should contact the floor in a 10 o'clock to 3 o'clock pattern when the brush is in motion.

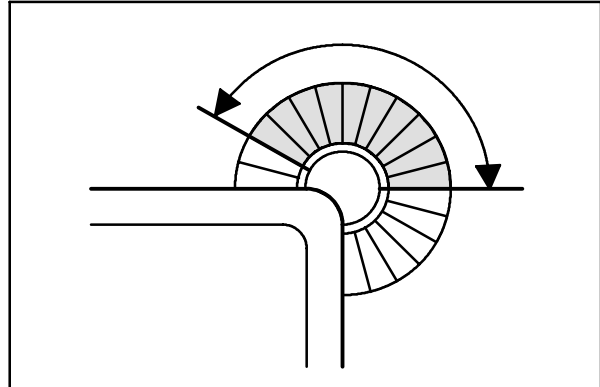

350327

Adjust the side brush pattern by the side brush down pressure knob. Turn the knob counter-clockwise to increase the brush contact with the sweeping surface, and clockwise to decrease the brush contact with the sweeping surface.

The side brush should be replaced when it no longer sweeps effectively for your application. A guideline length is when the remaining bristles measure 50 mm (2 in) in length. You may change the side brush sooner if you are sweeping light litter, or wear the bristles shorter if you are sweeping heavy debris.



## MAINTENANCE

### REPLACING SIDE BRUSH

1. Empty the debris hopper.
2. Set the machine parking brake.
3. Stop the engine.

**FOR SAFETY: Before leaving or servicing machine; stop on level surface, set parking brake, turn off machine and remove key.**

4. Remove the side brush retaining pin from the side brush drive shaft by pulling the pin keeper off over the end of the pin.
5. Slide the side brush off the side brush drive shaft.

*NOTE: Remove the drive hub and put it on the new brush if one is not installed.*

6. Slide the new side brush onto the side brush drive shaft.
7. Insert the side brush retaining pin through the side brush hub and shaft.
8. Secure the pin by clipping the pin keeper over the end of the pin.
9. Disengage the hopper support bar and lower the hopper.
10. Adjust the side brush pattern with the side brush down pressure knob.

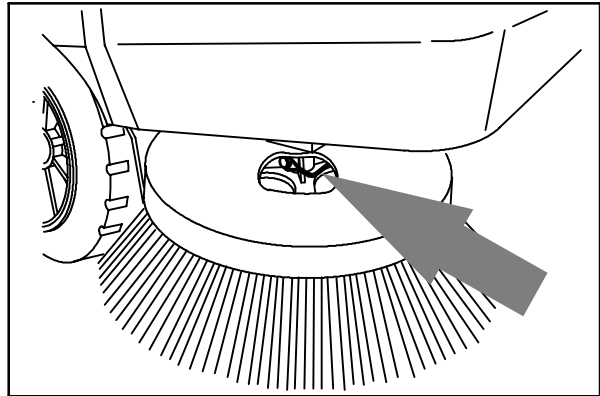

08019

### SIDE BRUSH GUARD

Rotate the side brush guard 90° every 200 hours of operation. Replace the brush guard after all four sides have been used.

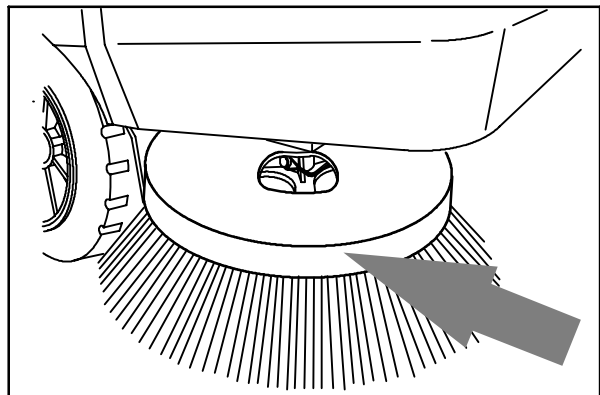

08049

**SCRUB BRUSHES**

Three disc-type scrub brushes scrub the floor. A spring lock clip holds the scrub brush onto the drive hub.

The scrub brushes should be checked daily for tangled wire or string, wear, and damage. The brushes should be replaced if large portions of the brush bristles are missing or if the remaining brush bristle measure 0.25 in (6 mm) or less in length.

*NOTE: Be sure to replace the scrub brushes in sets. Otherwise one scrub brush will be more aggressive than the other.*

**REPLACING THE SCRUB BRUSHES**

1. Set the machine parking brake.
2. Raise the scrub brushes.
3. Stop the engine.

**FOR SAFETY: Before leaving or servicing machine; stop on level surface, set parking brake, turn off machine and remove key.**

4. Press the brush spring clip ends together with your thumb and index finger to remove the scrub brush. Repeat for the other brushes.
5. Start with the center brush. Slide the new scrub brush under the scrub brush drive assembly.
6. Line up the scrub brush drive socket with the drive plug.
7. Press the brush spring clip together and lift the scrub brush onto the drive plug. Release the spring clip when the brush is in place. Repeat for the other brushes.

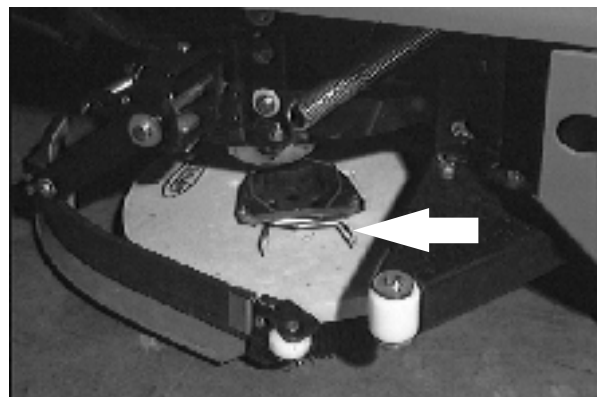

## SOLUTION SYSTEM

---

### RECOVERY TANK

The recovery tank stores recovered solution. The recovery tank should be drained and cleaned daily, or when the recovery tank full light comes on.

ES option: The ES filter should be cleaned daily. The ES filter can be rinsed while in the recovery tank through the right tank fill opening, or by removing the ES pump from the recovery tank.



### SOLUTION TANK

The solution tank contains the cleaning solution.

The solution tank does not require regular maintenance. If deposits form on the bottom of the tank, rinse the tank with a strong blast of warm water. The right tank can be flushed through the drain opening. Drain the tank with the solution tank drain hose.

The solution tank on machines with the ES option should be drained and cleaned daily. Rinse the solution outlet filters at the bottom of the tank through the drain access.

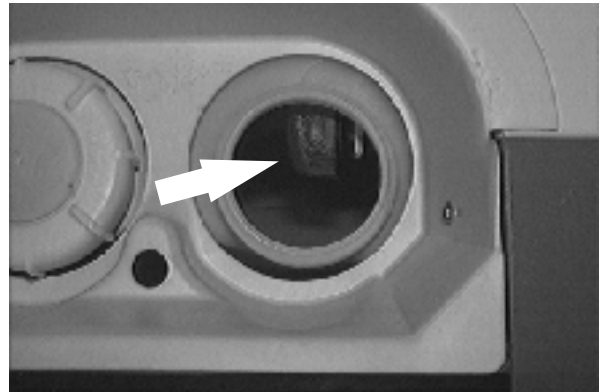

**FaST SYSTEM**

**FaST SUPPLY HOSE CONNECTOR**

The FaST supply hose connector is located on the side of the the FaST PAK holder. Soak the connector in warm water if detergent buildup is visible. When a FaST PAK carton is not installed, store the supply hose connector on the storing plug to prevent the hose from clogging.

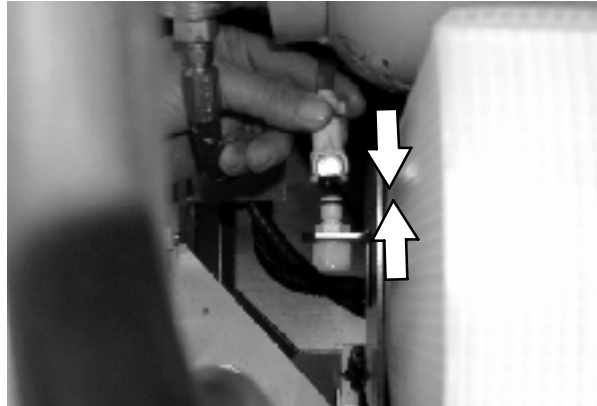

**FaST SYSTEM FILTER SCREEN**

The FaST system filter screen is located on top the scrub head and filters the water from the solution tank as it flows into the FaST system.

Remove the filter screen bowl and clean the filter screen after every 50 hours of machine operation. Empty the solution tank before removing the filter.

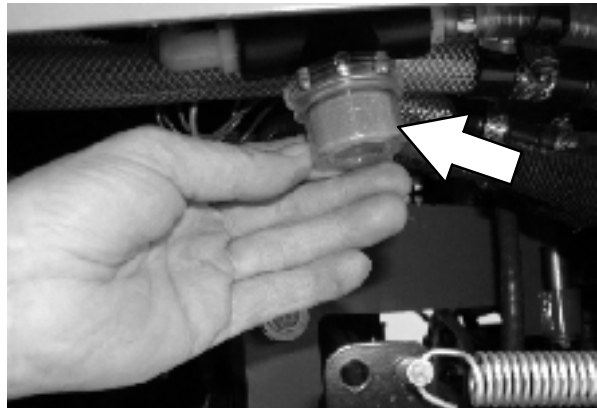

**FaST SYSTEM AIR PUMP FILTER**

The FaST system air pump filter is located on the top of the air pump.

Remove and clean out the air filter with compressed air after every 200 hours of FaST scrubbing.

**FOR SAFETY: When servicing machine, wear eye protection when using pressurized air or water.**

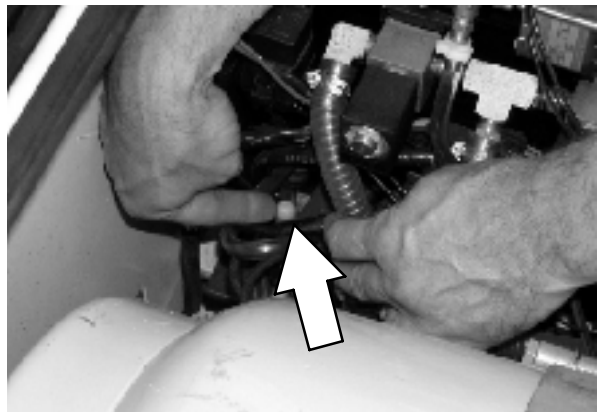

## SQUEEGEES

The squeegee channels water into the vacuum fan suction. The front blade channels the water, and the rear blade wipes the floor.

There are two types of squeegee blades available; one for smooth surfaces is standard on the machine, and one for rough surfaces is an option.

Check the squeegee blades for damage and wear daily. Rotate or replace either of the squeegee blades if the leading edge is torn or worn half-way through the thickness of the blade.

The squeegee can be adjusted for leveling and deflection. The deflection of the squeegee blades should be checked daily, or when scrubbing a different type of floor. The leveling of the squeegee should be checked every 100 hours of machine operation.

### LEVELING THE REAR SQUEEGEE

Leveling of the squeegee assures even contact the length of the squeegee blade with the surface being scrubbed. Make sure this adjustment is done on an even, level floor.

1. Lower the squeegee and drive the machine forward.
2. Shut off the engine and set the machine parking brake.

**FOR SAFETY: Before leaving or servicing machine; stop on level surface, set parking brake, turn off machine and remove key.**

3. Look at the deflection of the squeegee blade, over the full length of the squeegee blade.
4. If the deflection is not the same over the full length of the blade, loosen the turnbuckle jam nuts.
5. Turn the turnbuckle clockwise, from the rear of the machine, to increase the deflection at the ends of the squeegee. Turn the turnbuckle counter-clockwise, from the rear of the machine, to decrease the deflection at the ends of the squeegee blade. Be sure to turn both turnbuckles the **same** number of turns.

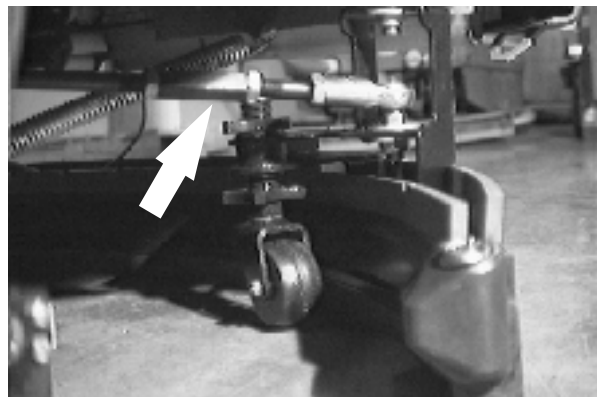



6. Tighten the jam nuts.

*NOTE: When tightening the turnbuckle jam nuts, make sure the rod ends are square with the squeegee frame, not tilted up.*

7. Start the engine and drive the machine forward again to check the squeegee blade deflection.
8. Readjust the squeegee blade deflection if necessary.

**ADJUSTING REAR SQUEEGEE BLADE DEFLECTION**

Deflection is the amount of curl the squeegee blade has when the machine moves forward with the squeegee lowered to the floor. The best deflection is when the squeegee wipes the floor just dry with a minimum amount of deflection.

1. Lower the squeegee and drive the machine forward.
2. Shut off the engine and set the machine parking brake.

**FOR SAFETY: Before leaving or servicing machine; stop on level surface, set parking brake, turn off machine and remove key.**

3. Look at the deflection of the squeegee blade, over the full length of the squeegee blade. The correct amount of deflection is 7 mm (0.25 in).
4. To adjust the amount of deflection, loosen the top knob on the two casters.
5. Turn the bottom knob clockwise to decrease the blade deflection. Turn the bottom knob counter-clockwise to increase the blade deflection. Be sure to turn both knobs the **same** number of turns. Tighten the top knobs on the casters.
6. Start the engine and drive the machine forward again to check the squeegee blade deflection. Readjust the squeegee blade deflection if necessary.
7. Raise the squeegee when finished.

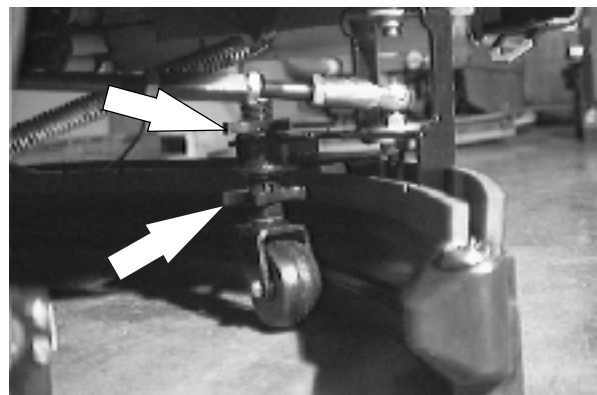

## SQUEEGEE BLADES

### REAR SQUEEGEE

The rear squeegee has two squeegee blades. Each blade has four wiping edges. To use them all, start with one wiping edge. To use the next wiping edge, rotate the blade end-for-end. To use the next wiping edge, rotate the top edges down, bottom edges up. To use the last edge, rotate the blade end-for-end.

Replace any worn or damaged squeegee blades.

### REPLACING OR ROTATING REAR SQUEEGEE BLADES

1. Make sure the squeegee is raised off the floor.
2. Shut the engine off and set the parking brake.

**FOR SAFETY: Before leaving or servicing machine; stop on level surface, set parking brake, turn off machine and remove key.**

3. Open the retaining band clamp and remove the squeegee blade.

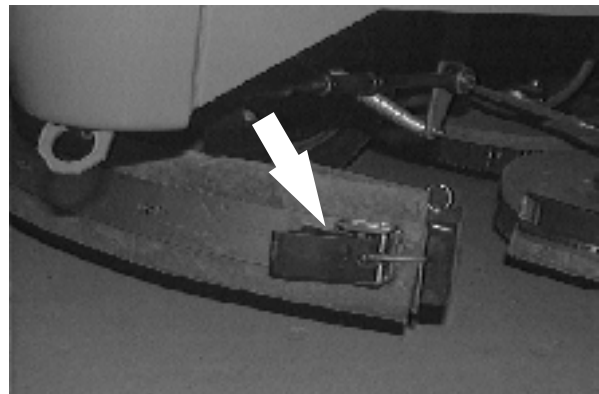

4. Replace or rotate the squeegee blade to allow a new edge to face the front of the machine.
5. Place the squeegee blade over the pins of the squeegee frame.
6. Position the retaining band over the squeegee blade. Latch the retaining band clamp.
7. Adjust the squeegee blade leveling and deflection as stated in *LEVELING THE REAR SQUEEGEE* and *ADJUSTING REAR SQUEEGEE BLADE DEFLECTION*.

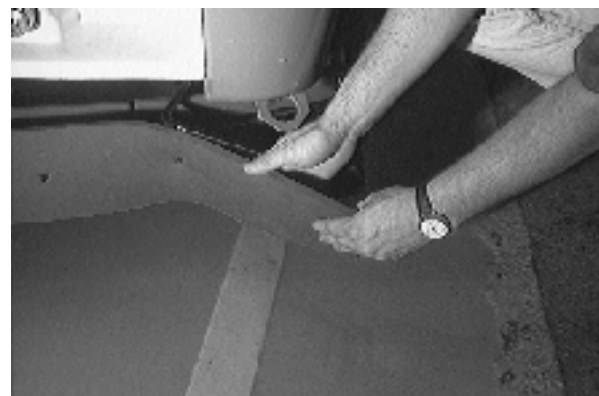

**SIDE SQUEEGEES**

The side squeegees control water spray and channel water into the path of the rear squeegee. Check the side squeegees for damage and wear daily. Replace the side squeegee blades whenever they become damaged or lose their shape or resilience. Replace the squeegee deflectors whenever they become worn.

**REPLACING SIDE SQUEEGEE BLADES**

1. Raise the scrub head.
2. Turn off the machine and set the machine parking brake.

**FOR SAFETY: Before leaving or servicing machine; stop on level surface, set parking brake, turn off machine and remove key.**

3. Remove the cotter pin, clevis pin, deflector, and the retainer bracket from the front of the side squeegee.
4. Pull the squeegee blade off the front of the squeegee frame.
5. Slide the new squeegee blade onto the frame.

*NOTE: Lubricating the squeegee frame where the squeegee makes contact will make for easier squeegee installation.*

6. Replace the retainer bracket, deflector, clevis pin, and cotter pin.
7. Repeat for the side squeegee on the other side of the scrub head.

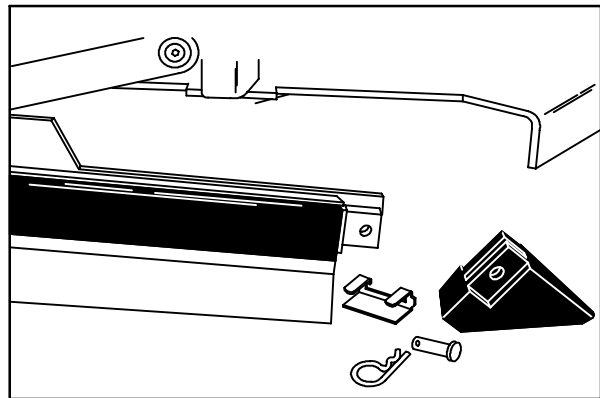

05942

## SKIRTS AND SEALS

### HOPPER LIP SKIRTS

The hopper lip skirts are located on the bottom rear of the hopper. The skirts float over debris and help deflect that debris into the hopper. The hopper lip skirts consist of five bottom lip segments and two additional side lip segments.

Check the hopper lip skirts for wear or damage daily.

Replace the hopper lip skirts when they no longer touch the floor.

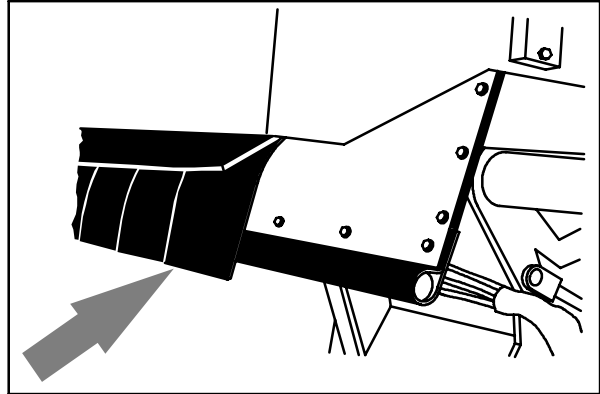

08020

### HOPPER SIDE SKIRT

The hopper side skirt is located on the left side of the hopper.

Check the hopper side skirt for wear or damage daily.

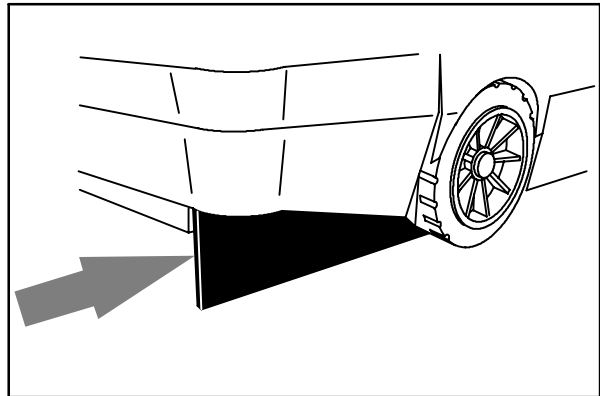

08214

### BRUSH DOOR SKIRTS

The brush door skirts are located on the bottom of each of the two main brush doors. The long skirt should clear the floor by 3 to 6 mm (0.12 to 0.25 in). The inner skirt should be angled so that the rear corner touches the floor, and the front corner is 6 mm (0.25 in) above the corner of the long skirt.

Check the skirts for wear or damage and adjustment daily.

*NOTE: The brush door skirts have slotted holes to allow for a ground clearance adjustment. The door must be closed for proper adjustment.*

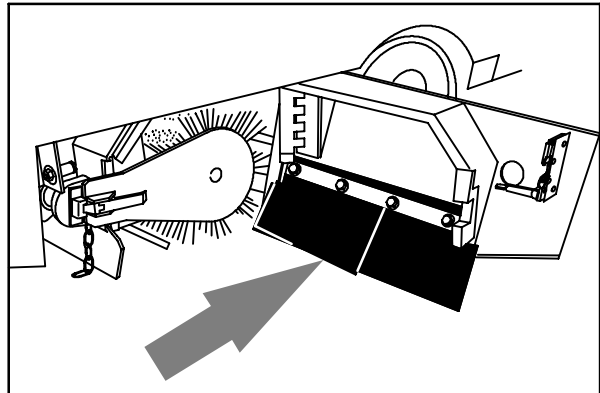

08001

**REAR SKIRTS**

The two rear skirts are located on the bottom rear of the main brush compartment. The vertical skirt should clear the floor up to 5 mm (0.25 in) in dusty conditions, and touch the floor otherwise. The recirculation skirt is self-adjusting.

Check the skirts for wear or damage and adjustment daily.

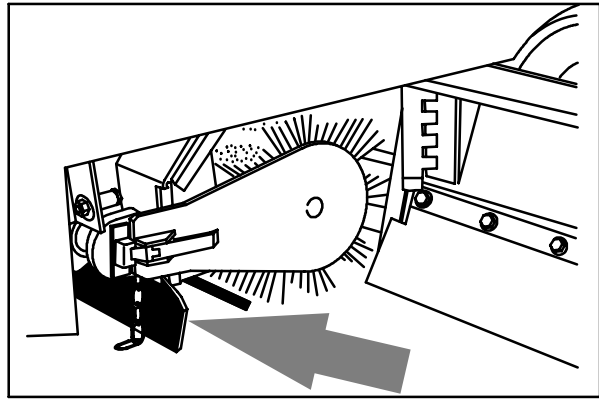

08021

**BRUSH DOOR SEALS**

The brush door seals are located on both main brush doors and on corresponding portions of the main frame.

Check the seals for wear or damage every 100 hours of operation.

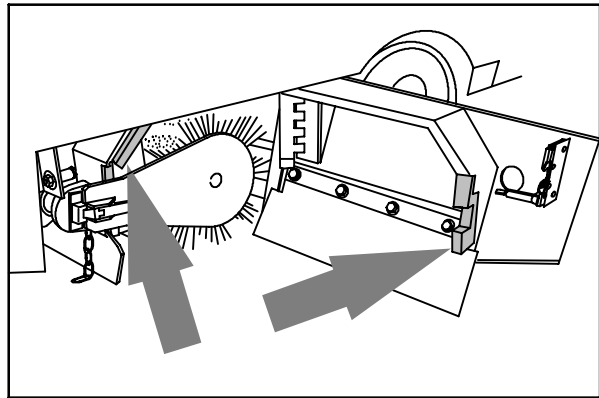

08022

**HOPPER SEALS**

The hopper seals are located on the top and side portions of the machine frame that contact the hopper.

Check the seals for wear or damage every 100 hours of operation.

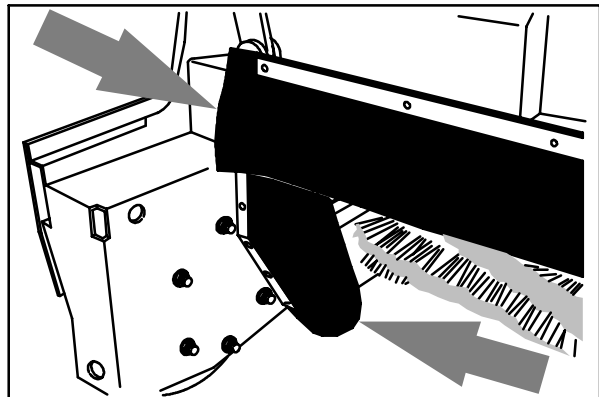

08023

**HOPPER INSPECTION DOOR SEAL**

The hopper inspection door seal is located on the hopper and seals the front of the debris hopper.

Check the seal for wear or damage every 100 hours of operation.

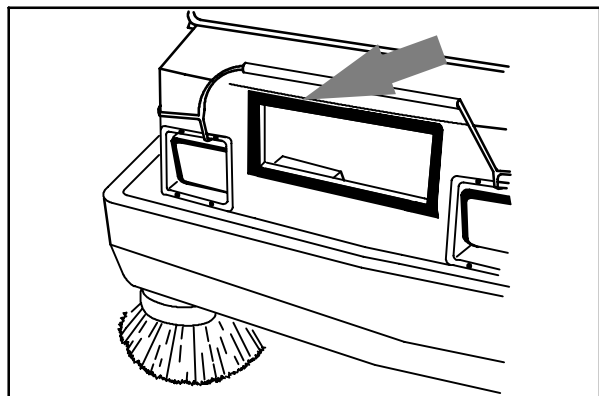

08024

## MAINTENANCE

### HOPPER DOOR SEALS

The hopper door seals are located on the hopper door. They seal the hopper when the hopper door is closed.

Check the seals for wear or damage every 100 hours of operation.

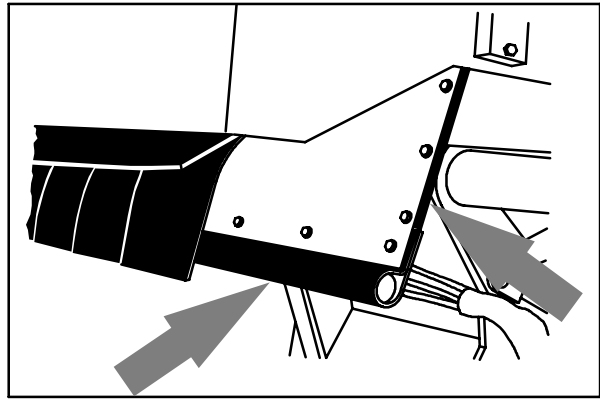

08025

### HOPPER COVER SEAL

The hopper cover seal is located on the top edges of the hopper insert. It seals the hopper filter compartment.

Check the seal for wear or damage every 100 hours of operation.

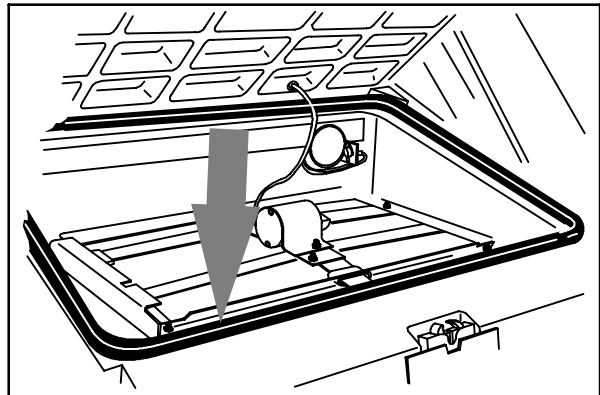

08026

### HOPPER DUST SEAL

The hopper dust seal is located under the hopper insert along the top of the hopper.

Check the seal for wear or damage every 100 hours of operation. You can reach the seal by removing the hopper insert.

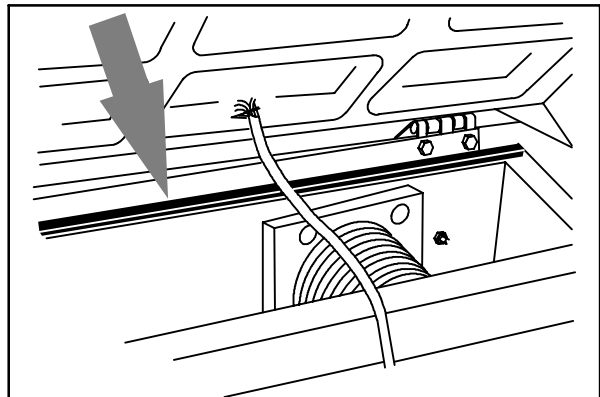

08153

### HOPPER VACUUM FAN SEAL

The hopper vacuum fan seal is mounted on the inside of the hopper around the vacuum fan inlet.

Check the seal for wear or damage every 100 hours of operation. You can reach the seal by removing the hopper insert.

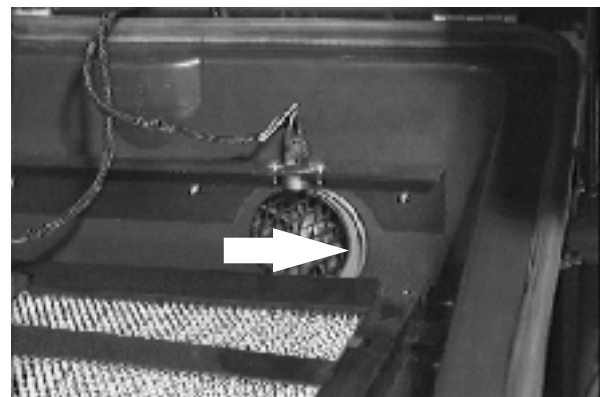

**COVER AND DOOR SEALS**

Seals are located on the covers and doors.

Check the seals for wear or damage every 100 hours of operation

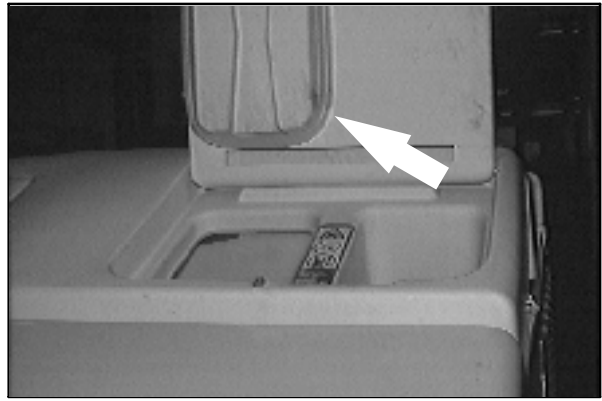

---

**BRAKES AND TIRES**

---

**SERVICE BRAKES**

The mechanical service brakes are located on the front wheels. The brakes are operated by the foot brake pedal and connecting cables.

Check the brake adjustment every 200 hours of operation.

**PARKING BRAKE**

The parking brake is set with the parking brake lever that locks the brake pedal.

**TIRES**

The machine tires are solid. Check the tires every 100 hours of operation for damage.

**REAR WHEEL**

Torque the rear wheel nuts twice in the pattern shown to 122 to 149 Nm (90 to 110 ft lb) after the first 50-hours of operation, and every 800 hours there after.

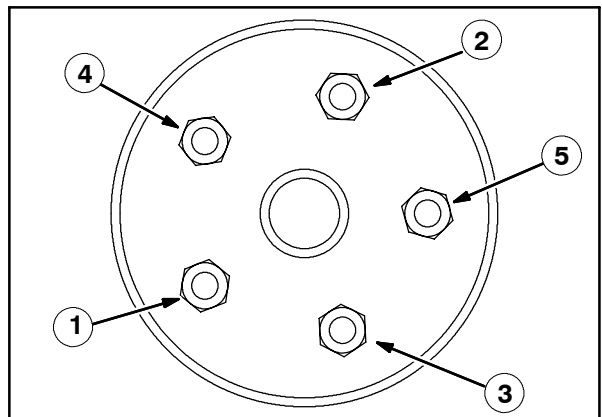

## PUSHING, TOWING, AND TRANSPORTING THE MACHINE

### PUSHING OR TOWING THE MACHINE

If the machine becomes disabled, it can be pushed from the front or rear, but towed only from the rear.

The propelling pump has a bypass valve to prevent damage to the hydraulic system when the machine is being pushed or towed. This valve allows a disabled machine to be moved for a *very short distance* and at a speed to not exceed 1.6 kp/h (1 mph). The machine is NOT intended to be pushed or towed a long distance or at a high speed.

**ATTENTION! Do not push or tow machine for a long distance and without using the bypass valve, or the machine hydraulic system may be damaged.**

Turn the bypass valve 90° from the normal position before pushing or towing the machine. **The illustration shows the bypass valve in the pushing or towing position.**

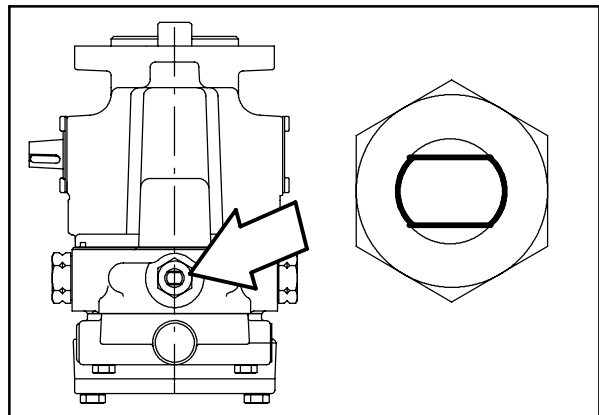



**TRANSPORTING THE MACHINE**

1. Position the rear of the machine at the loading edge of the truck or trailer.

**FOR SAFETY: Use truck or trailer that will support the weight of the machine.**

*NOTE: Empty the hopper, recovery tank, and solution tank before transporting the machine.*

2. If the loading surface is not horizontal or is higher than 380 mm (15 in) from the ground, use a winch to load machine.

If the loading surface is horizontal AND is 380 mm (15 in) or less from the ground, the machine may be driven onto the truck or trailer.

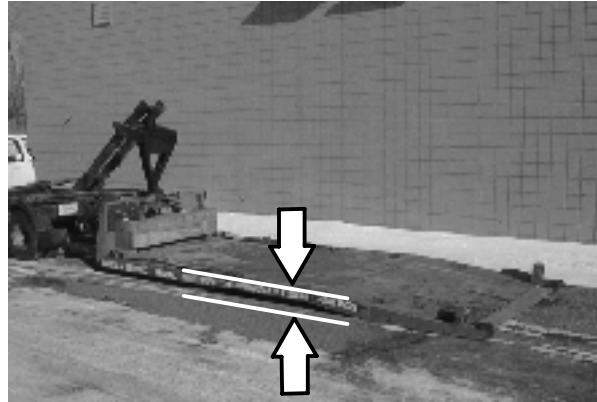

3. To winch the machine onto the truck or trailer, attach the winching chains in the holes at the bottom of the rear bumper.



**WARNING: Hot bumper. Keep away.**

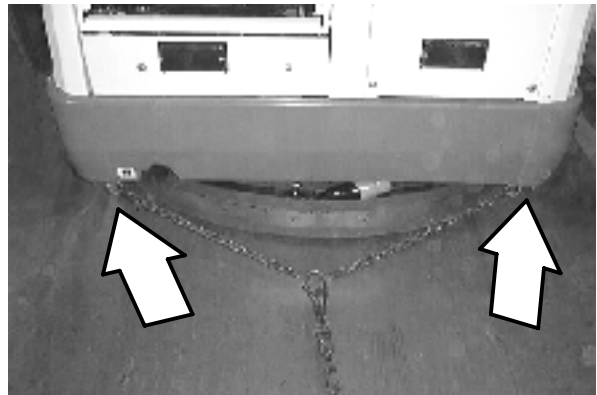

If the machine has the optional rear tie down brackets, attach the winching chains to them.



**WARNING: Hot bumper. Keep away.**

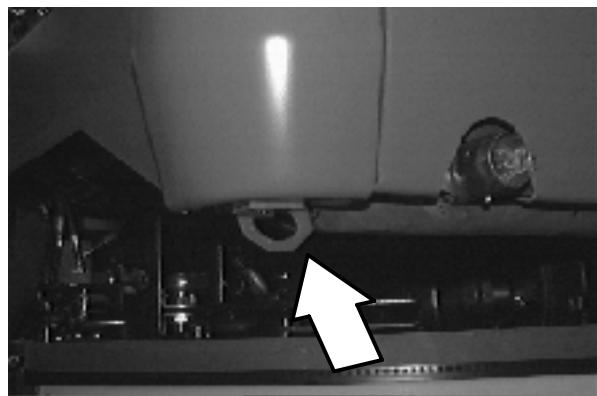

## MAINTENANCE

4. Turn the bypass valve 90° from the normal position before winching the machine onto the truck or trailer. See *PUSHING OR TOWING THE MACHINE* section of this manual. Make sure the machine is centered.

**FOR SAFETY: When loading machine onto truck or trailer, use winch. Do not drive the machine onto the truck or trailer unless the loading surface is horizontal AND is 380 mm (15 in) or less from the ground.**

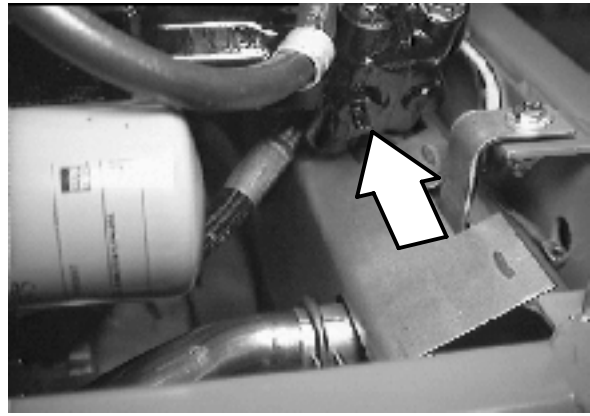

5. Position the machine onto the truck or trailer as far as possible. If the machine starts to veer off the centerline of the truck or trailer, stop and turn the steering wheel to center the machine.

- Set the parking brake, lower the scrub head and block the machine tires. Tie down the machine to the truck or trailer before transporting.

The front tie-down locations are the holes in the wheel pockets at the front of the machine frame.



If the machine has the optional front tie down brackets above the front tires, attach the winching chains to them.

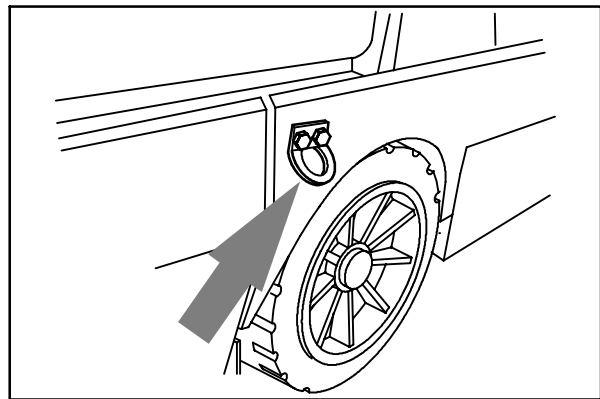

08152

The rear tie down locations are in the holes at the bottom of the rear bumper. If the machine has the optional rear tie down brackets, use them to tie down the machine.



**WARNING: Hot bumper. Keep away.**

- If the loading surface is not horizontal or is higher than 380 mm (15 in) from the ground, use a winch to unload machine.

If the loading surface is horizontal AND is 380 mm (15 in) or less from the ground, the machine may be driven off the truck or trailer.

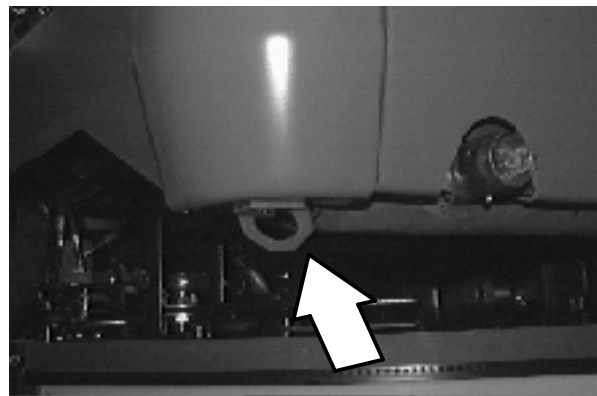

**FOR SAFETY: When unloading machine off truck or trailer, use winch. Do not drive the machine off the truck or trailer unless the loading surface is horizontal AND 380 mm (15 in) or less from the ground.**

## MACHINE JACKING

Empty the hopper, recovery tank, and solution tank before jacking the machine. You can jack up the machine for service at the designated locations. Use a hoist or jack that will support the weight of the machine. Always stop the machine on a flat, level surface and block the tires before jacking the machine up.

**FOR SAFETY: Before leaving or servicing machine; stop on level surface, set parking brake, turn off machine and remove key.**

The front jacking locations are on the flat bottom edge of the front of the machine frame next to the front tires.

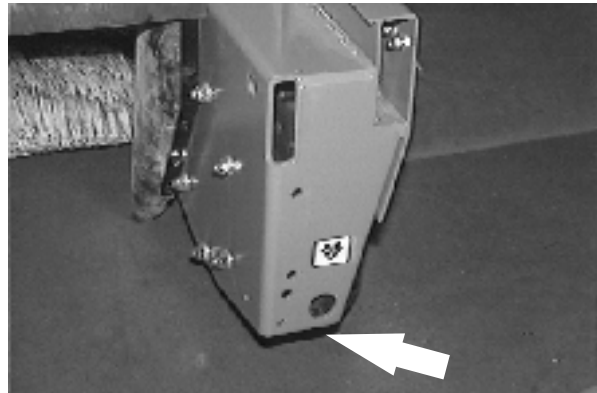

The rear jacking location is the left corner of the rear bumper.

**FOR SAFETY: When servicing machine, block machine tires before jacking machine up.**

**FOR SAFETY: When servicing machine, jack machine up at designated locations only. Block machine up with jack stands.**

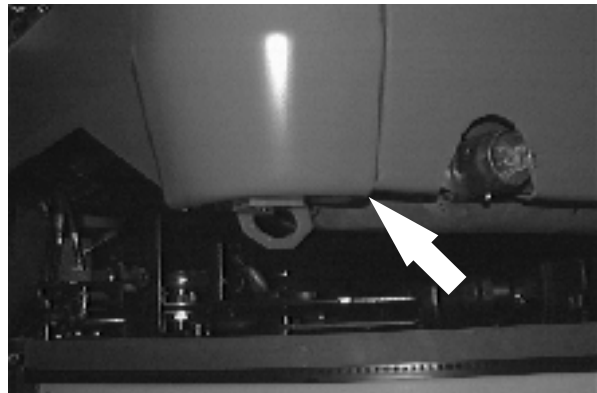

**WARNING: Hot bumper. Keep away.**

## STORING MACHINE

Before storing the machine for an extended time, the machine needs to be prepped to lessen the chance of rust, sludge, and other undesirable deposits from forming. Contact Tennant service personnel.

**SPECIFICATIONS**

**GENERAL MACHINE DIMENSIONS/CAPACITIES**

Item	Dimension/capacity
Length	2970 mm (117 in)
Width with side brush	1610 mm (63.5 in)
Height	1625 mm (64 in)
Height with overhead guard	2125 mm (83.7 in)
Track	1330 mm (52.38 in)
Wheelbase	1625 mm (63.88 in)
Main sweeping brush diameter	355 mm (14 in)
Main sweeping brush length	1145 mm (45 in)
Scrub brush diameter	405 mm (16 in)
Side brush diameter	585 mm (23 in)
Sweeping path width	1145 mm (45 in)
Sweeping path width with side brush	1525 mm (60 in)
Squeegee width	1490 mm (58.7 in)
Scrubbing path width	1220 mm (48 in)
Main sweeping brush pattern width	50 to 65 mm (2 to 2.5 in)
Hopper weight capacity	545 kg (1200 lb)
Hopper volume capacity	400 L (14 ft <sup>3</sup> )
Dust filter area	6.9 m <sup>2</sup> (74 ft <sup>2</sup> )
Solution tank	227 L (60 gal)
Recovery tank	227 L (60 gal)
Detergent tank (option)	18.9 L (5 gal)
Total capacity with ES (option)	379 L (100 gal)
GVWR	3133 kg (6900 lb)
Ceiling height minimum dumping clearance	2490 mm (98 in)

**GENERAL MACHINE PERFORMANCE**

Item	Measure
Maximum forward speed	12.9 km/h (8 mph)
Maximum reverse speed	4.8 km/h (3 mph)
Minimum aisle turn width, left	3530 mm (139 in)
Minimum turning radius, right	3235 mm (128 in)
Minimum turning radius, left	2270 mm (90 in)
Maximum rated incline for transport of machine	8°/14.1%
Maximum rated incline for scrubbing/sweeping	6°/10.5%

# SPECIFICATIONS

## FaST SYSTEM

Item	Measure
Solution pump	12 Volt DC, 11A, 11.6 LPM (3.0 GPM) open flow, 45 psi bypass setting
Low solution flow rate	2.7 LPM (0.7 GPM)
High solution flow rate	5.4 LPM (1.4 GPM)
Detergent pump	12 Volt DC
Low concentrate flow rate	2.6 CC/Minute (0.085 Liquid Ounces/Minute)
High concentrate flow rate	5.2 CC/Minute (0.17 Liquid Ounces/Minute)
Air pump	12 Volt DC, 0.6 Maximum Amp draw
Air pump flow rate	8.7 LPM (0.3 CFM) open flow

## POWER TYPE

Engine	Type	Ignition	Cycle	Aspiration	Cylinders	Bore	Stroke
Kubota V2203-B	Piston	Diesel	4	Natural	4	87 mm (3.34 in)	92.4 mm (3.64 in)
	Displacement		Net power, governed		Net power, maximum		
	2200 cc (134.08 cu in)		32.8 kw (44 hp) @ 2400 rpm		36.6 kw (49 hp) @ 2800 rpm		
	Fuel		Cooling system		Electrical system		
	Diesel Fuel tank: 37.9 L (10 gal)		Water/ethylene glycol antifreeze		12 V nominal		
			Total: 17 L (4.5 gal)		50 A alternator		
			Radiator: 6 L (1.6 gal)				
	Idle speed, no load		(Fast) governed speed, under load		Engine lubricating oil without filter		
1500 ± 25 rpm		2400 ± 25 rpm		6.15 L (6.5 qt) SAE-CC/CD rated engine oil			

**STEERING**

Type	Power source	Emergency steering
Rear wheel, hydraulic cylinder and rotary valve controlled	Hydraulic accessory pump	Manual

**HYDRAULIC SYSTEM**

System	Capacity	Fluid Type
Hydraulic reservoir	37.8 L (10 gal)	TENNANT part no. 65869 - above 7° C (45° F)
Hydraulic total	53 L (14 gal)	TENNANT part no. 65870 - below 7° C (45° F)

**BRAKING SYSTEM**

Type	Operation
Service brakes	Mechanical drum brakes (2), one per front wheel, cable actuated
Parking brake	Utilize service brakes, cable actuated

**TIRES**

Location	Type	Size	Pressure
Front (2)	Solid	5 x 18 in	-
Rear (1)	Solid	6 x 18 in	-

# SPECIFICATIONS

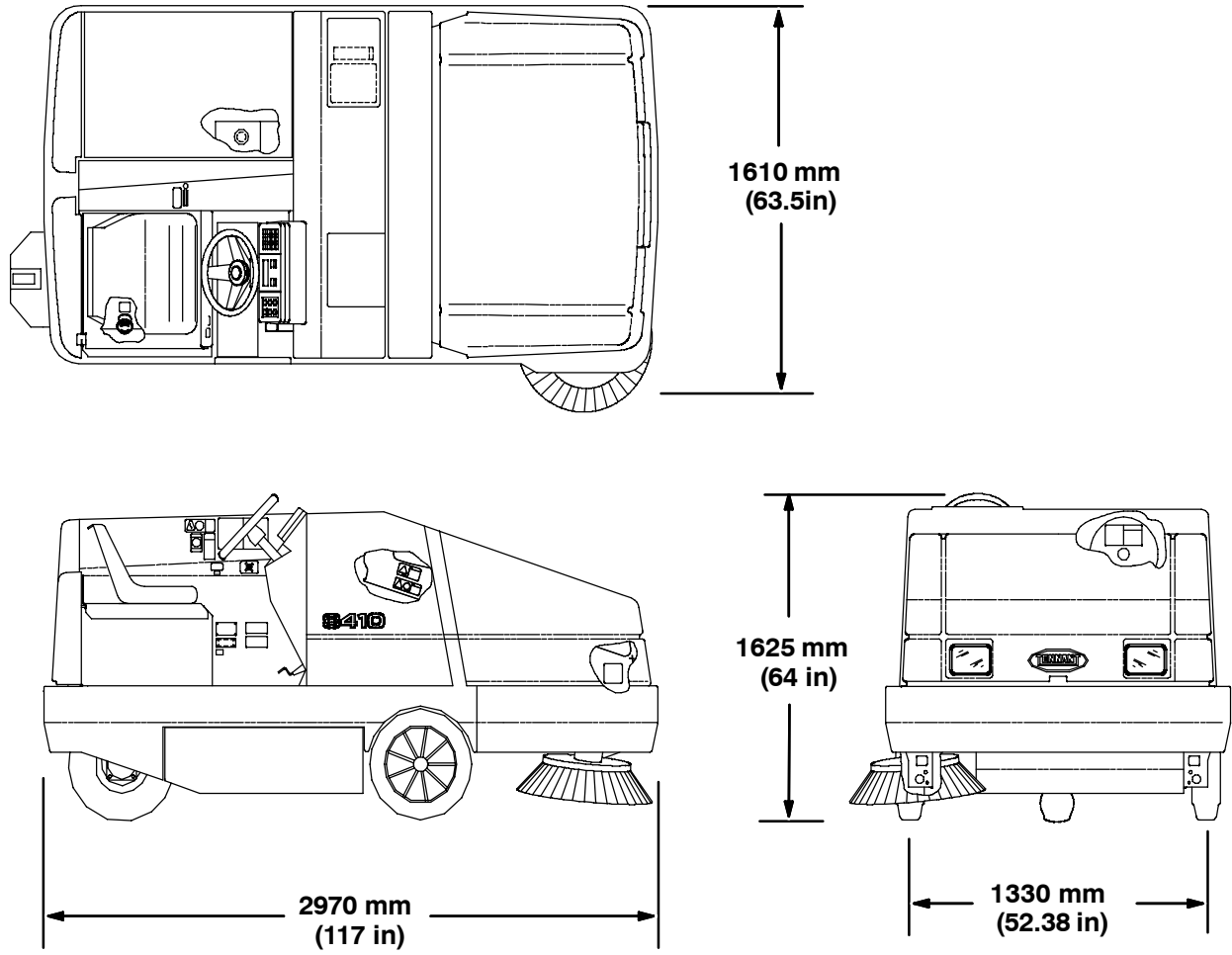

11087

## MACHINE DIMENSIONS



## INDEX

**A**

Adjusting rear squeegee deflection, 87  
 Air filter, 71  
   Dust cap, 71  
   Element, 71  
 Air filter indicator, 71  
 Aisle turn, 99

**B**

Battery, 73  
   Charging system, Light, 17  
 Bearings, Front wheel, 67  
 Belts, 74  
   Engine, 74  
 Brake pedal, 13  
 Brakes, 33, 93  
   Parking, Adjustment, 93  
   Service, 93  
   System specifications, 101  
 Brushes, 38–41, 54, 77–84  
   Adjusting main brush taper, 80  
   Checking main sweep brush pattern, 79–81  
   Checking side brush pattern, 81  
   Door latch, 29  
   Door seals, 91  
   Door skirts, 90  
   Main brush, 38  
   Main brush down pressure knob, 27  
   Main sweep brush, 77–81  
   Main sweep brush bristle length, 77  
   Main sweep brush speed 1 switch, 16  
   Main sweep brush speed 2 switch, 17  
   Replacing main sweep brush, 78–80  
   Replacing scrub brushes, 83–85  
   Replacing side brush, 82–84  
   Scrub brush switch, 22  
   Scrub brushes, 39, 83–85  
   Side brush, 39, 81–83  
   Side brush bristle length, 81  
   Side brush down pressure knob, 27  
   Side brush switch, 15  
 Button, Horn, 24  
 Bypass valve, 94

**C**

Capacities, 99  
 Chains, 74  
   Static drag, 74

Charging system light, 17  
 Circuit breakers, 26  
 Clogged filter light, 19  
 Control panel  
   Clogged filter light, 19  
   Detergent flow switch, 21  
   Edge clean switch, 21  
   Engine oil pressure, 17, 18  
   Engine water temperature light, 18  
   ES switch, 20  
   Filter shaker switch, 14  
   Fuel level gauge, 20  
   Hazard light switch, 13  
   Hopper door switch, 15  
   Hopper lower switch, 15  
   Hopper raise switch, 14  
   Hopper temperature light, 19  
   Hourmeter, 20  
   Main brush speed 2 switch, 17  
   Main sweep brush speed 1 switch, 16  
   Maintenance mode light, 18  
   OK light, 19  
   Operating lights switch, 14  
   Recovery tank full light, 18  
   Scrub brush switch, 22  
   Side brush switch, 15  
   Squeegee and vacuum fan switch, 23  
   Sweep vacuum fan switch, 16  
 Controls, 11  
   Brake pedal, 13  
   Charging system light, 17  
   Circuit breakers, 26  
   Clogged filter light, 19  
   Detergent flow switch, 21  
   Directional pedal, 12  
   Edge clean switch, 21  
   Engine oil pressure light, 18  
   Engine water temperature light, 18  
   ES switch, 20  
   FaST solution flow switch (option), 28  
   FaST switch (option), 28  
   Filter shaker switch, 14  
   Fuel level gauge, 20  
   Fuse, 29  
   Hazard light switch, 13  
   Hopper door switch, 15  
   Hopper lower lever, 15  
   Hopper raise switch, 14  
   Hopper temperature light, 19  
   Horn button, 24  
   Hourmeter, 20  
   Ignition switch, 24  
   Latches, 29  
   Main brush down pressure knob, 27  
   Main brush speed 2 switch, 17

- Main sweep brush speed 1 switch, 16
- Maintenance mode, 18
- OK light, 19
- Operating lights switch, 14
- Operation, 12–25
- Parking brake pedal, 13
- Recovery tank full light, 18
- Scrub brush switch, 22
- Side brush down pressure knob, 27
- Side brush switch, 15
- Solution flow switch, 27
- Squeegee and vacuum fan switch, 23
- Steering column tilt lever, 25
- Steering wheel, 24
- Sweep vacuum fan switch, 16
- Symbols, 9–11
- Throttle lever, 23
- Turn signal switch, 25

**Covers**

- Hopper, Seals, 92
- Recovery tank, Latch, 29
- Seals, 93

**D**

- Debris hopper, 75–78
- Demister cover, Seals, 93
- Detergent flow switch, 21
- Dimensions, 99
- Directional pedal, 12
- Disengaging hopper support bar, 56–58
- Doors
  - Brush
    - Latch, 29
    - Seals, 91
    - Skirts, 90
  - Engine side, Latch, 29
  - Hopper, Seals, 92
  - Hopper Inspection, Seal, 91
  - Hopper, Pivots, 67
- Double scrubbing, 49
- Draining and cleaning tanks, 50–52
- Dust filter, 75–76
  - Changing, 75–77
  - Cleaning, 75

**E**

- Edge clean switch, 21
- Electrical
  - Circuit breakers, 26
  - Fuse, 29
  - Ignition switch, 24

- Emptying the hopper, 42–44
- Engaging hopper support bar, 55–57
- Engine, 70–73
  - Air filter, 71
  - Air filter indicator, 33, 71
  - Belt, 74
  - Coolant temperature, Light, 18
  - Cooling system, 70
  - Fuel filter, 72
  - Fuel lines, 72
  - Lubrication, 66
  - Oil capacity, 66
  - Oil level, 33
  - Oil pressure, Light, 18
  - Priming fuel system, 72
  - Side door latch, 29
  - Specifications, 100

- Engine oil pressure light, 18
- Engine water temperature light, 18
- ES filter, 84
- ES switch, 20

**F**

- FaST, System, 85
- FaST pak agent, Installing, 34–36
- FaST pak agent installation, 34–36
- FaST solution flow switch, 28
- FaST Supply Hose Connector, 85
- FaST switch, 28
- FaST System, 85
  - FaST supply hose connector, 85
- FaST system, 32
- FaST System Air Pump Filter, 85
- FaST System Filter Screen, 85
- Filling the tanks, 44–46
- Filter
  - FaST System Air Pump Filter, 85
  - FaST System Filter Screen, 85
- Filter shaker switch, 14
- Fuel, 54
- Fuel filter, 72
- Fuel level, 33
- Fuel level gauge, 20
- Fuel lines, 72
- Fuel system
  - Fuel lines, 72
  - Priming, 72
- Fuse, 29

**G**

Gauge, Fuel level, 20  
Grease fittings, Rear wheel support, 66

**H**

Hazard light switch, 13  
Hopper, 75–78  
  Changing dust filter, 75–77  
  Clogged filter, Light, 19  
  Cover seal, 92  
  Disengaging hopper support bar, 56–58  
  Door, 15  
  Door pivots, 67  
  Door seals, 92  
  Dust filter, 75–76  
  Dust seal, 92  
  Engaging hopper support bar, 55–57  
  Filter cleaning, 75  
  Filter shaker, 14  
  Inspection door seal, 91  
  Lift arm pivots, 67  
  Lip skirts, 90  
  Lower, 15  
  Raise, 14  
  Seals, 91  
  Side skirt, 90  
  Support bar, 30  
  Temperature, Light, 19  
  Thermo-sentry, 19, 77  
  Vacuum fan seal, 92  
Hopper door pivots, 67  
Hopper door switch, 15  
Hopper lift arm pivots, 67  
Hopper lower switch, 15  
Hopper raise switch, 14  
Hopper support bar, 30  
Hopper temperature light, 19  
Horn button, 24  
Hourmeter, 20  
How the machine works, 31  
Hydraulic fluid, 68  
Hydraulic fluid reservoir, 68  
Hydraulic hoses, 69

Hydraulics, 68–70  
  Fluid, 68–70  
  Fluid filter, 68  
  Fluid level, 68  
  Hoses, 69  
  Propelling motor, 69  
  Reservoir, 68  
  System specifications, 101

**I**

Ignition switch, 24

**J**

Jack points, 98–100

**K**

Knobs  
  Main brush down pressure, 27  
  Side brush down pressure, 27

**L**

Latches, 29  
  Engine side door, 29  
  Main brush doors, 29  
  Radiator, grill, 29  
  Recovery tank cover, 29  
Leveling the rear squeegee, 86–88  
Levers, Steering column tilt, 25  
Lights  
  Charging system, 17  
  Clogged filter, 19  
  Engine oil pressure, 18  
  Engine water temperature, 18  
  Hazard light switch, 13  
  Hopper temperature, 19  
  Maintenance mode, 18  
  OK, 19  
  Operating lights switch, 14  
  Recovery tank full light, 18  
Lubrication, 66–68  
  Engine, 66  
  Front wheel bearings, 67  
  Rear squeegee casters, 67  
  Rear wheel support, 66

**M**

Machine components, 8  
Machine dimensions, 102  
Machine jacking, 98–100  
Machine leaks, 54  
Machine tie down location, 97  
Main brush, 38–39  
    Adjust brush taper, 80  
    Door latch, 29  
    Door seals, 91  
    Door skirts, 90  
    Down pressure, 27  
    Speed 2 switch, 17  
Main brush down pressure knob, 27  
Main sweep brush, 77–81  
    Bristle length, 77  
    Checking brush pattern, 79–81  
    Maintenance, 77  
    Replacing, 78–80  
    Speed 1 switch, 16  
Main sweep brush speed 1 switch, 16  
Main sweep brush speed 2 switch, 17  
Maintenance, 64–85  
    Intervals, 64–65  
    Recommended, 7  
Maintenance chart, 64–65  
Maintenance mode light, 18  
Motors, Propelling, 69

**O**

OK, Light, 19  
OK light, 19  
Operating lights switch, 14  
Operation, 7–64  
Operation on inclines, 57  
Operator Responsibility, 7–8  
Operator seat, 30  
Options, 58–62  
    Detergent flow switch, 21  
    ES switch, 20  
    Hazard light switch, 13  
    Turn signal switch, 25  
    Vacuum wand, 58–61

**P**

Parking brake, 93  
Parking brake pedal, 13  
Pedals  
    Brake, 13  
    Directional, 12  
    Parking brake, 13  
Post-operation checklist, 54–56  
Pre-operation checklist, 33–35  
Priming fuel system, 72  
Pushing machine, 94  
Pushing or towing the machine, 94  
Pushing, towing, and transporting machine, 94

**R**

Radiator, 70  
    Coolant level, 70  
    Coolant type, 70  
    Flushing system, 70  
    Grill latch, 29  
    Hoses, 70  
Rear squeegee, 88–90  
    Deflection, 87  
    Leveling, 86–88  
    Replacing blades, 88–90  
Rear squeegee casters, 67  
Rear wheel, 93  
Recovery tank, 54, 84  
    Cover latch, 29  
    Full light, 18  
Recovery tank full light, 18  
Replacing rear squeegee blades, 88–90  
Replacing side squeegee blades, 89

**S**

Safety  
    Disengaging hopper support bar, 56–58  
    Engaging hopper support bar, 55–57  
    Hopper support bar, 30  
    Labels, 5–7  
    Precautions, 3–5  
Screen, FaST System Filter Screen, 85  
Scrub brush switch, 22

- Scrub brushes, 39, 83–85
  - Check, 54
  - Replacing, 83–85
  - Switch, 22
- Scrub head, 77
- Scrubbing, 46–48
  - Double, 49
- Scrubbing and brush information, 38–41
- Seals, 90–94
  - Brush doors, 91
  - Demister cover, 93
  - Hopper, 91
  - Hopper cover, 92
  - Hopper door, 92
  - Hopper dust, 92
  - Hopper inspection door, 91
  - Hopper vacuum fan seal, 92
- Seat, 30
  - Adjustment, 30
  - Lift, 30
- Service records, 54
- Side brush, 39, 81–83
  - Bristle length, 81
  - Checking brush pattern, 81
  - Down pressure, 27
  - Replacing, 82–84
  - Switch, 15
- Side brush down pressure knob, 27
- Side brush guard, 82
- Side brush switch, 15
- Side squeegee, Blades, 89
- Side squeegees, 89
  - Replacing blades, 89
- Skirts, 90–92
  - Brush doors, 90
  - Hopper Lip, 90
  - Hopper side, 90
  - Rear, 91
- Solution flow switch, 27
- Solution system, 84
  - Detergent flow switch, 21
  - ES switch, 20
  - Flow switch, 27
  - Recovery tank, 84
  - Solution tank, 84
- Solution tank, 84
  - Drain and clean, 54
- Specifications, 99–101
  - Braking system, 101
  - FaST System, 100
  - Hydraulic system, 101
  - Machine capacities, 99
  - Machine dimensions, 99
  - Machine performance, 99
  - Power type, 100
  - Steering, 101
  - Tires, 101
- Squeegee and vacuum fan switch, 23
- Squeegees, 86–88
  - Blades, 88–90
  - Deflection, 33, 54, 87
  - Leveling, 86–88
  - Rear, 88–90
  - Replacing rear blades, 88–90
  - Replacing side blades, 89
  - Side, 89
  - Switch, 23
- Starting the machine, 36–37
- Static drag chain, 74
- Steering, 33
  - Specifications, 101
- Steering column tilt lever, 25
- Steering wheel, 24
- Stop scrubbing, 49
- Stop sweeping, 41
- Stop the machine, 52–54
- Storing machine, 98
- Sweep vacuum fan switch, 16
- Sweeping, 40–42
- Sweeping and brush information, 38–41
- Switches
  - Detergent flow, 21
  - Edge clean, 21
  - ES, 20
  - FaST, 28
  - FaST solution flow, 28
  - Filter shaker, 14
  - Hazard light, 13
  - Hopper door, 15
  - Hopper lower, 15
  - Hopper raise, 14
  - Ignition, 24
  - Main brush speed 2 switch, 17
  - Main sweep brush speed 1 switch, 16
  - Operating lights, 14
  - Scrub brush, 22
  - Side brush, 15
  - Solution flow, 27
  - Squeegee and vacuum fan, 23
  - Sweep vacuum fan, 16
  - Turn signal, 25

## T

Thermo-sentry, 77  
Thermo-sentry, 19  
Throttle, Lever, 23  
Throttle lever, 23  
Tie down location, 97  
Tires, 93  
    Rear wheel, 93  
    Specifications, 101  
Towing machine, 94  
Transporting machine, 94  
Transporting the machine, 95  
Travel speed, 99  
Troubleshooting, 61–63  
Turn signal switch, 25

## V

Vacuum fan, Switch, 23  
Vacuum hoses, 54  
Vacuum wand, 58–61